

JEFFERSON COUNTY COMMUNITY MINISTRIES THE NEIGHBOR PROJECT SITE PLAN FOR 202 RACETRACK STREET BUILDING RENOVATION

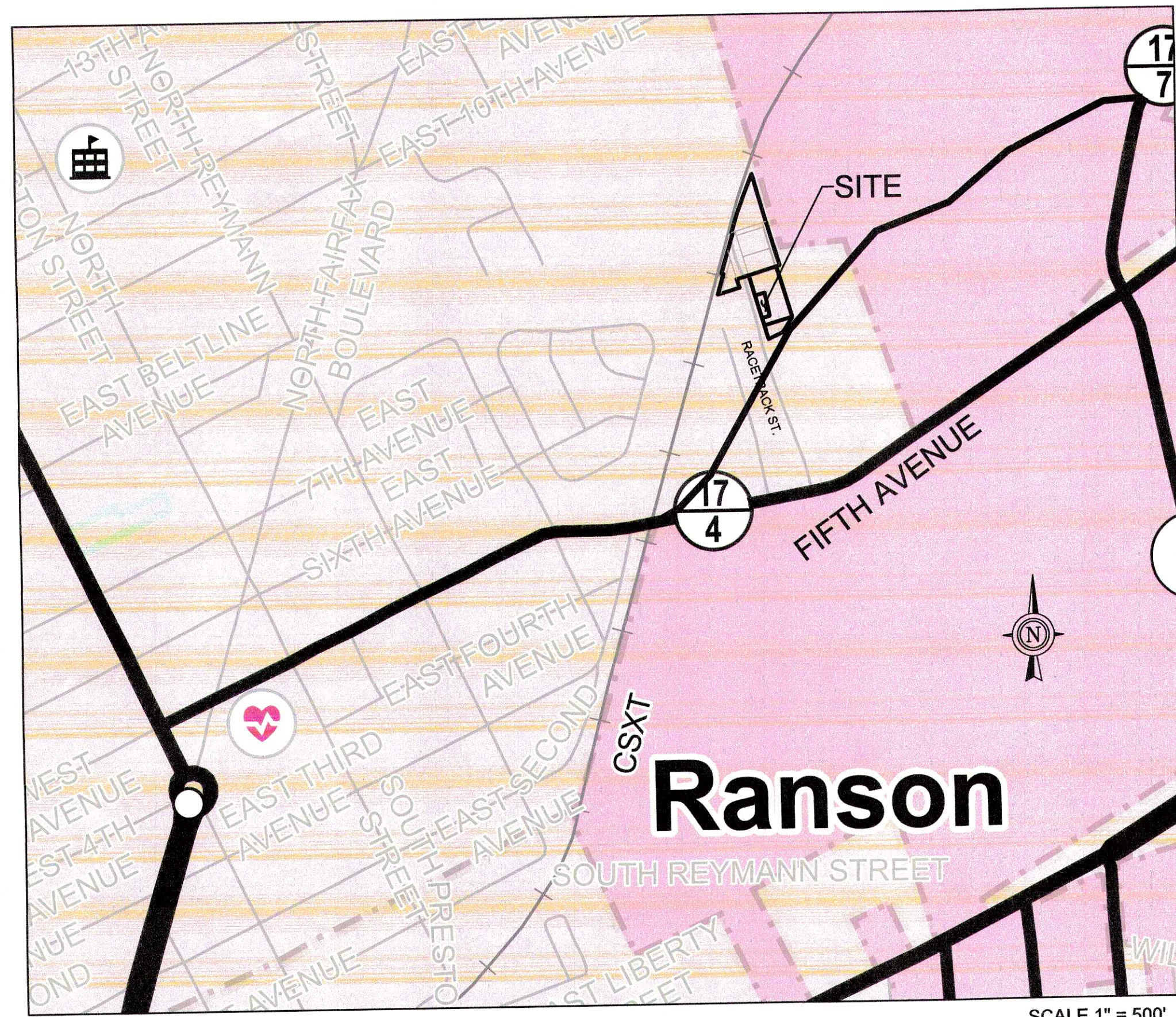

VICINITY MAP

SCALE 1" = 500'

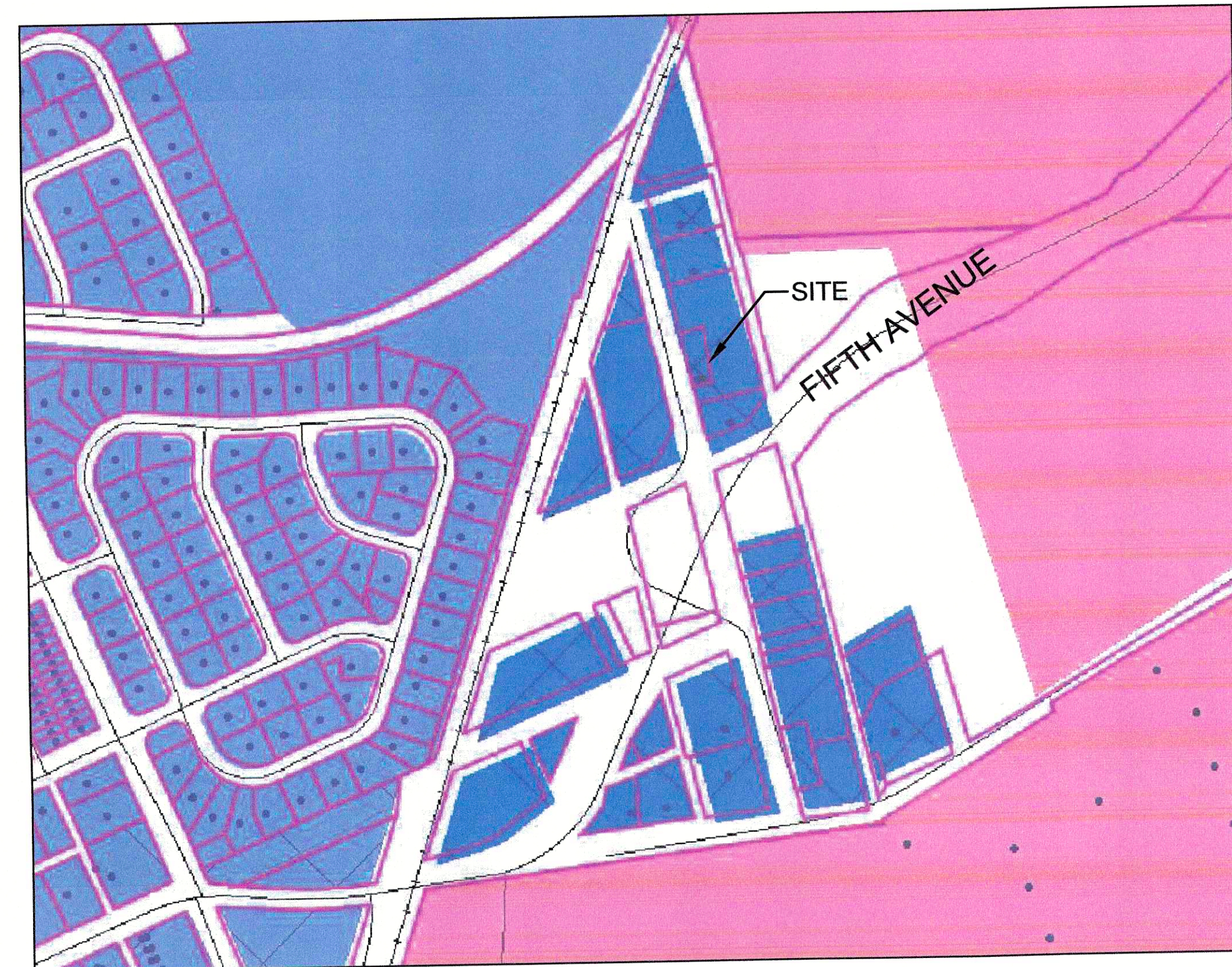

ZONING MAP

NOT TO SCALE

ZONING LEGEND

<input checked="" type="checkbox"/> Zoning (RN)	T20 - Rural Open
RR - Rural Reserve	T3 - Sub-Urban
R-6 - R-6 Residential	T4 - General Neighborhood
R-7 - R-7 Residential	T40 - General Neighborhood Open
HC - Highway Commercial	T5L - Town Center Limited
RC - Racetrack Commercial	T5 - Town Center
I - Industrial	SD - Special District
T1 - Natural	MUX - Mixed Use - Retired
T2 - Rural	NCX - Neighborhood Center Mix - Retired
T2O - Rural Open	UCX - Urban Commercial - Retired

CITY OF RANSON - SITE WORK MILESTONE INSPECTIONS		INSPECTOR'S INITIALS & DATE
THE DEVELOPER SHALL REQUEST COUNTY ENGINEER INSPECTIONS MINIMUM OF 48 HOURS IN ADVANCE. INSPECTIONS SHALL BE REQUESTED ACCORDING TO THE TABLE OF MILESTONES SHOWN BELOW:		
1.	INSTALLATION OF SEDIMENT & EROSION CONTROL DEVICES PRIOR TO BEGINNING SITE GRADING.	
2.	ROADWAY AND/OR PARKING LOT SUBGRADE PROOF ROLL PRIOR TO PLACING STONE BASE.	
3.	ROADWAY AND/OR PARKING LOT STONE BASE DEPTH CHECK PRIOR TO PLACING ASPHALT OR CONCRETE PAVEMENT.	
4.	WATER SYSTEM AND SANITARY SEWER SYSTEM INSPECTION AND APPROVAL BY CHARLES TOWN UTILITY BOARD PRIOR TO BACKFILLING OF TRENCHES.	
5.	FINAL INSPECTION INCLUDING BUT NOT LIMITED TO: SEEDING & MULCHING, ROADWAY & PARKING LOT PAVING, SIDEWALKS, STORM DRAINAGE AND STORMWATER MANAGEMENT SYSTEMS, TRAFFIC CONTROL SIGNS & PAVEMENT MARKINGS, LANDSCAPING, ETC.	

NOTE: THE CITY ENGINEER MAY ACCEPT "THIRD-PARTY" INSPECTION AND CERTIFICATION REPORTS IN PLACE OF INSPECTIONS PERFORMED BY THE JEFFERSON COUNTY ENGINEERING DEPARTMENT, UPON PRIOR APPROVAL. THIRD PARTY INSPECTION REPORTS SHALL BE SUBMITTED IN THE FORMAT SPECIFIED BY THE CITY ENGINEER.

SHEET INDEX	
SHEET NO.	SHEET TITLE
C000	COVER SHEET
C001	GENERAL NOTES
C100	EXISTING CONDITIONS
C101	DEMOLITION PLAN
C102	SITE PLAN
C300	EROSION AND SEDIMENT CONTROL PLAN AND DETAILS
C500	DETAILS

CITY OF RANSON CONSTRUCTION NOTES

- A. EROSION & SEDIMENT CONTROL MEASURES SHALL BE IN PLACE AND INSPECTED PRIOR TO PERFORMING ANY SIGNIFICANT EARTH DISTURBING ACTIVITIES AND SITE GRADING.
- B. EARTH WORK SHALL BE COMPACTED TO THE PERCENTAGES OF MAXIMUM DRY DENSITY IN ACCORDANCE WITH AASHTO T99C, AS SHOWN BELOW:

A. ROADWAYS.....	98%
B. PARKING LOTS FOR HEAVY TRUCKS.....	98%
C. PARKING LOTS FOR PASSENGER VEHICLES.....	98%
D. UTILITY LINE TRENCHES.....	98%
E. BUILDING PADS.....	100%
- THE ABOVE COMPACTION REQUIREMENTS SHALL BE CERTIFIED BY A PROFESSIONAL ENGINEER OR A SOILS TECHNICIAN UNDER THE DIRECTION OF A PROFESSIONAL ENGINEER, AND ACCEPTABLE TO THE CITY ENGINEER.
- C. CHANGES AND REVISIONS TO THE CONSTRUCTION PLANS AND SPECIFICATIONS SHALL NOT BE MADE UNLESS FIRST SUBMITTED IN WRITING AND APPROVED BY THE CITY ENGINEER AND ANY OTHER AGENCIES, AS DEEMED APPROPRIATE.
- D. WORK ZONE TEMPORARY TRAFFIC CONTROL ALONG A PUBLIC ROAD SHALL BE IN ACCORDANCE WITH WEST VIRGINIA DIVISION OF HIGHWAY REQUIREMENTS AND APPROVAL.
- E. SEVENTY-TWO (72) HOURS PRIOR TO EXCAVATION IN PUBLIC RIGHT-OF-WAYS OR IN AREAS SERVED BY UNDERGROUND UTILITIES, CALL MISS UTILITY 1-800-245-4848.

LIST OF PERMITS

- WVDH UTILITY PERMIT # - NOT APPLICABLE
- WV BUREAU OF HEALTH # - NOT APPLICABLE
- WVDEP NPDES PERMIT # - NOT APPLICABLE. - LOD < 1 ACRE

CITY OF RANSON - COMPLETE LIST OF WAIVERS/VARIANCES			
ORDINANCE	SECTION OF ORDINANCE	DESCRIPTION OF WAIVER OR VARIANCE	DATE GRANTED
P & Z	5.9 PARKING LOCATION STANDARDS	WAIVER TO ALLOW HEAD IN PARKING	8/20/2024

THE RANSON PLANNING COMMISSION APPROVES THIS SITE PLAN ON _____ WITH THE FOLLOWING CONDITIONS:

- _____
- _____
- _____

Mark T. ... 7-5-2024
PLANNING COMMISSION PRESIDENT DATE

THE OWNER OF THIS PROPERTY HEREBY AFFIRMS THAT THESE PLANS MEET THE REQUIREMENTS OF THE RANSON ZONING AND SUBDIVISION ORDINANCES AND THE ABOVE CONDITIONS OF APPROVAL SET FORTH BY THE RANSON PLANNING COMMISSION.

Ken A. ... 8/28/24
OWNER DATE

SITE PLAN FOR JCCM - 202 RACETRACK STREET BUILDING RENOVATION

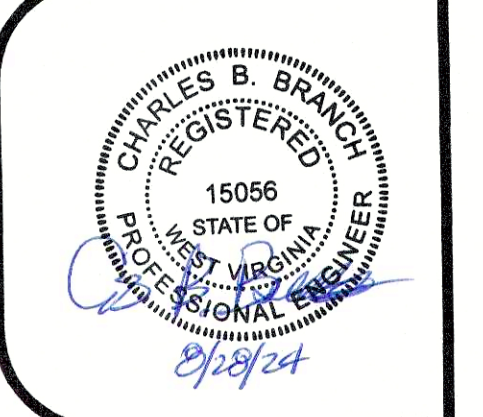

OWNER/DEVELOPER:
JEFFERSON COUNTY COMMUNITY MINISTRIES, INC.
ADDRESS:
238 W. WASHINGTON ST.
CHARLES TOWN, WV 25414
PHONE:
571-213-4651
ATTN:
KEITH LOWRY

REVISIONS

No.	ITEM	DATE
1.	CITY REVIEW COMMENTS	8/1/2024
2.	CITY REVIEW COMMENTS	8/13/2024
3.	CITY REVIEW COMMENTS	8/28/2024
4.	CITY REVIEW COMMENTS	8/27/2024

PROJ. NO.: 2309065.00
DATE: 7/11/2024
SHEET NO.:
C000
COPYRIGHT 2024 ALPHA ASSOCIATES, INC. ALL RIGHTS RESERVED.

SITE PLAN FOR
JCCM - 202 RACETRACK STREET
BUILDING RENOVATION
RANSON CORP. T.M. 5 PARS. 179 & 179.1 D.B. 1309 Pg. 424
JEFFERSON COUNTY, WEST VIRGINIA
COVER SHEET

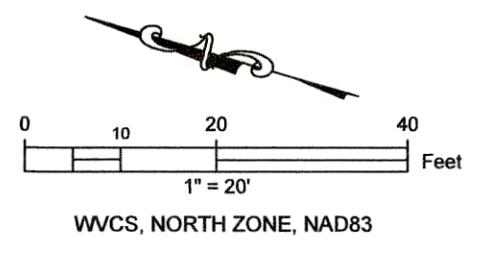

SITE PLAN
FOR
JCCM - 202 RACETRACK STREET
BUILDING RENOVATION



OWNER/DEVELOPER:
JEFFERSON COUNTY
COMMUNITY MINISTRIES, INC.
ADDRESS:
238 W. WASHINGTON ST.
CHARLES TOWN, WV, 25414
PHONE:
571-213-4651
ATTN:
KEITH LOWRY

REVISIONS

No.	ITEM	DATE
1.	CITY REVIEW COMMENTS	8/1/2024
2.	CTUB REVIEW COMMENTS	8/13/2024
3.	CTUB REVIEW COMMENTS	8/25/2024
4.	CITY REVIEW COMMENTS	8/27/2024

PROJ. NO.: 2309065.00
DATE: 7/11/2024
SHEET NO.:

C100

COPYRIGHT 2024 ALPHA ASSOCIATES, INC.
ALL RIGHTS RESERVED

SITE PLAN
FOR
JCCM - 202 RACETRACK STREET
BUILDING RENOVATION
 RANSON CORP, T.M. 5 PARS. 179 & 179.1 D.B. 1309 Pg. 424
 JEFFERSON COUNTY, WEST VIRGINIA

EXISTING CONDITIONS

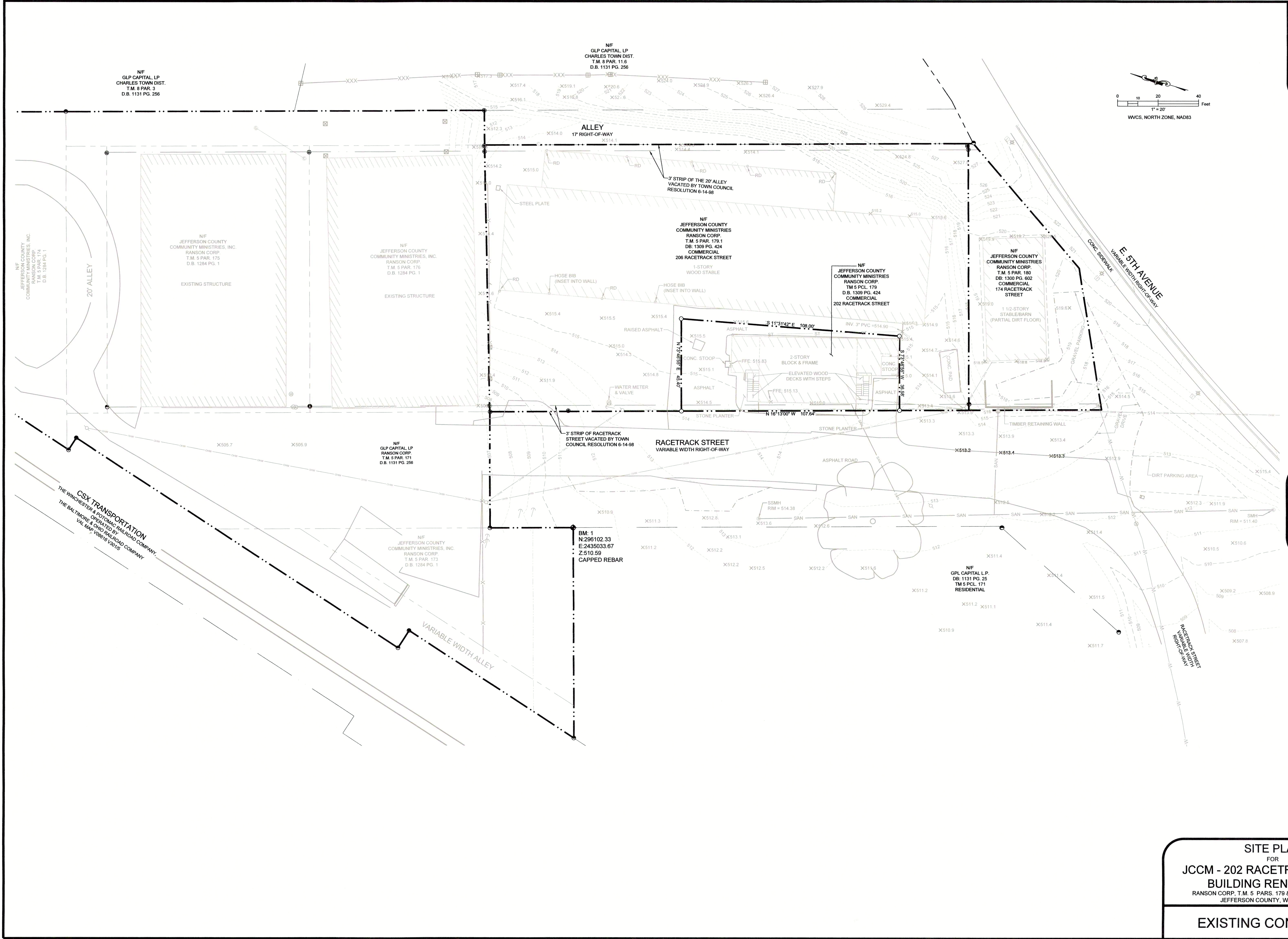

SITE PLAN
FOR
JCCM - 202 RACETRACK STREET
BUILDING RENOVATION

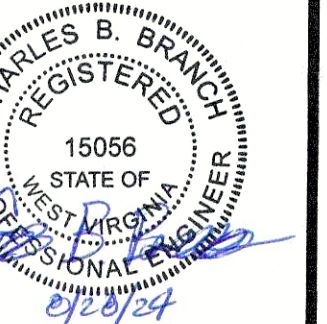

OWNER/DEVELOPER:
JEFFERSON COUNTY
COMMUNITY MINISTRIES, INC.
ADDRESS:
238 W. WASHINGTON ST.
CHARLES TOWN, WV, 25414
PHONE:
571-213-4651
ATTN:
KEITH LOWRY

REVISIONS

No.	ITEM	DATE
1.	CITY REVIEW COMMENTS	8/1/2024
2.	CTUB REVIEW COMMENTS	8/1/2024
3.	CTUB REVIEW COMMENTS	8/26/2024
4.	CITY REVIEW COMMENTS	8/27/2024

PROJ. NO.: 2309065.00
DATE: 7/11/2024
SHEET NO.:

C101

COPYRIGHT 2024 ALPHA ASSOCIATES, INC.
ALL RIGHTS RESERVED

SITE PLAN
FOR
JCCM - 202 RACETRACK STREET
BUILDING RENOVATION
RANSON CORP., T.M. 5 PARS. 179 & 179.1 D.B. 1309 PG. 424
JEFFERSON COUNTY, WEST VIRGINIA

DEMOLITION PLAN

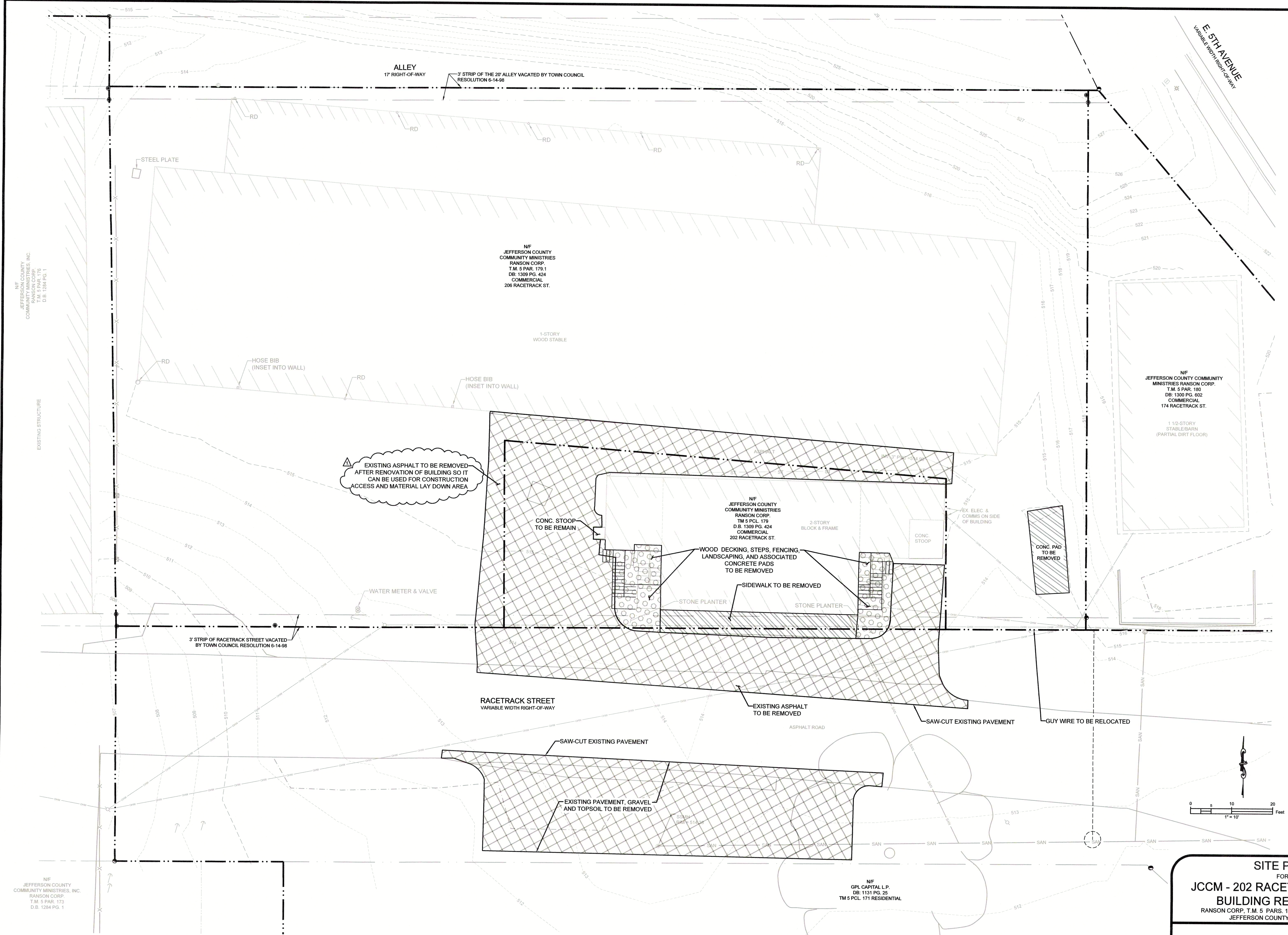

N/F
JEFFERSON COUNTY
COMMUNITY MINISTRIES, INC.
RANSON CORP.
T.M. 5 PAR. 176
D.B. 1284 PG. 1

EXISTING STRUCTURE

N/F
JEFFERSON COUNTY
COMMUNITY MINISTRIES
RANSON CORP.
T.M. 5 PAR. 179.1
D.B. 1309 PG. 424
COMMERCIAL
206 RACETRACK ST.

1-STORY
WOOD STABLE

N/F
JEFFERSON COUNTY COMMUNITY
MINISTRIES RANSON CORP.
T.M. 5 PAR. 180
D.B. 1300 PG. 602
COMMERCIAL
174 RACETRACK ST.

1 1/2-STORY
STABLE/BARN
(PARTIAL DIRT FLOOR)

N/F
JEFFERSON COUNTY
COMMUNITY MINISTRIES
RANSON CORP.
T.M. 5 PCL. 179
D.B. 1309 PG. 424
COMMERCIAL
202 RACETRACK ST.

2-STORY
BLOCK & FRAME

EX. ELEC &
COMMS ON SIDE
OF BUILDING

CONC. PAD
TO BE
REMOVED

EXISTING ASPHALT TO BE REMOVED
AFTER RENOVATION OF BUILDING SO IT
CAN BE USED FOR CONSTRUCTION
ACCESS AND MATERIAL LAY DOWN AREA

CONC. STOOP
TO BE REMAIN

WOOD DECKING, STEPS, FENCING,
LANDSCAPING, AND ASSOCIATED
CONCRETE PADS
TO BE REMOVED

SIDEWALK TO BE REMOVED

STONE PLANTER

STONE PLANTER

WATER METER & VALVE

3' STRIP OF RACETRACK STREET VACATED
BY TOWN COUNCIL RESOLUTION 6-14-98

RACETRACK STREET
VARIABLE WIDTH RIGHT-OF-WAY

EXISTING ASPHALT
TO BE REMOVED

SAW-CUT EXISTING PAVEMENT

ASPHALT ROAD

SAW-CUT EXISTING PAVEMENT

GUY WIRE TO BE RELOCATED

EXISTING PAVEMENT, GRAVEL
AND TOPSOIL TO BE REMOVED

N/F
GPL CAPITAL LP.
D.B. 1131 PG. 25
T.M. 5 PCL. 171 RESIDENTIAL

N/F
JEFFERSON COUNTY
COMMUNITY MINISTRIES, INC.
RANSON CORP.
T.M. 5 PAR. 173
D.B. 1284 PG. 1

SITE PLAN
FOR
JCCM - 202 RACETRACK STREET
BUILDING RENOVATION

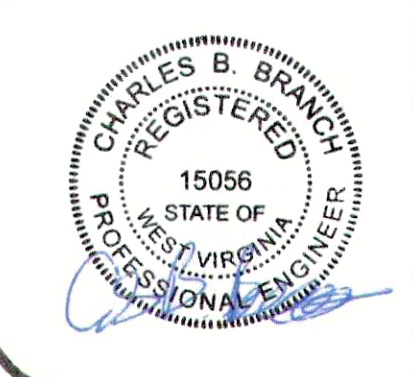

OWNER/DEVELOPER:
JEFFERSON COUNTY
COMMUNITY MINISTRIES, INC.
ADDRESS:
238 W. WASHINGTON ST.
CHARLES TOWN, WV, 25414
PHONE:
571-213-4551
ATTN:
KEITH LOWRY

REVISIONS

No.	ITEM	DATE
1	CITY REVIEW COMMENTS: 8/1/2024	
2	CTUB REVIEW COMMENTS: 8/13/2024	
3	CTUB REVIEW COMMENTS: 8/28/2024	
4	CITY REVIEW COMMENTS: 8/27/2024	
5	NEW WATER SERVICE LINE: 1/24/2025	

PROJ. NO.: 2309065.00
DATE: 7/11/2024
SHEET NO.:

C102

COPYRIGHT © 2024 ALPHA ASSOCIATES, INC. ALL RIGHTS RESERVED.

SITE PLAN
FOR
JCCM - 202 RACETRACK STREET
BUILDING RENOVATION
RANSON CORP. T.M. S. PARS. 179 & 175.1 D.B. 1309 PG. 424
JEFFERSON COUNTY, WEST VIRGINIA

SITE PLAN

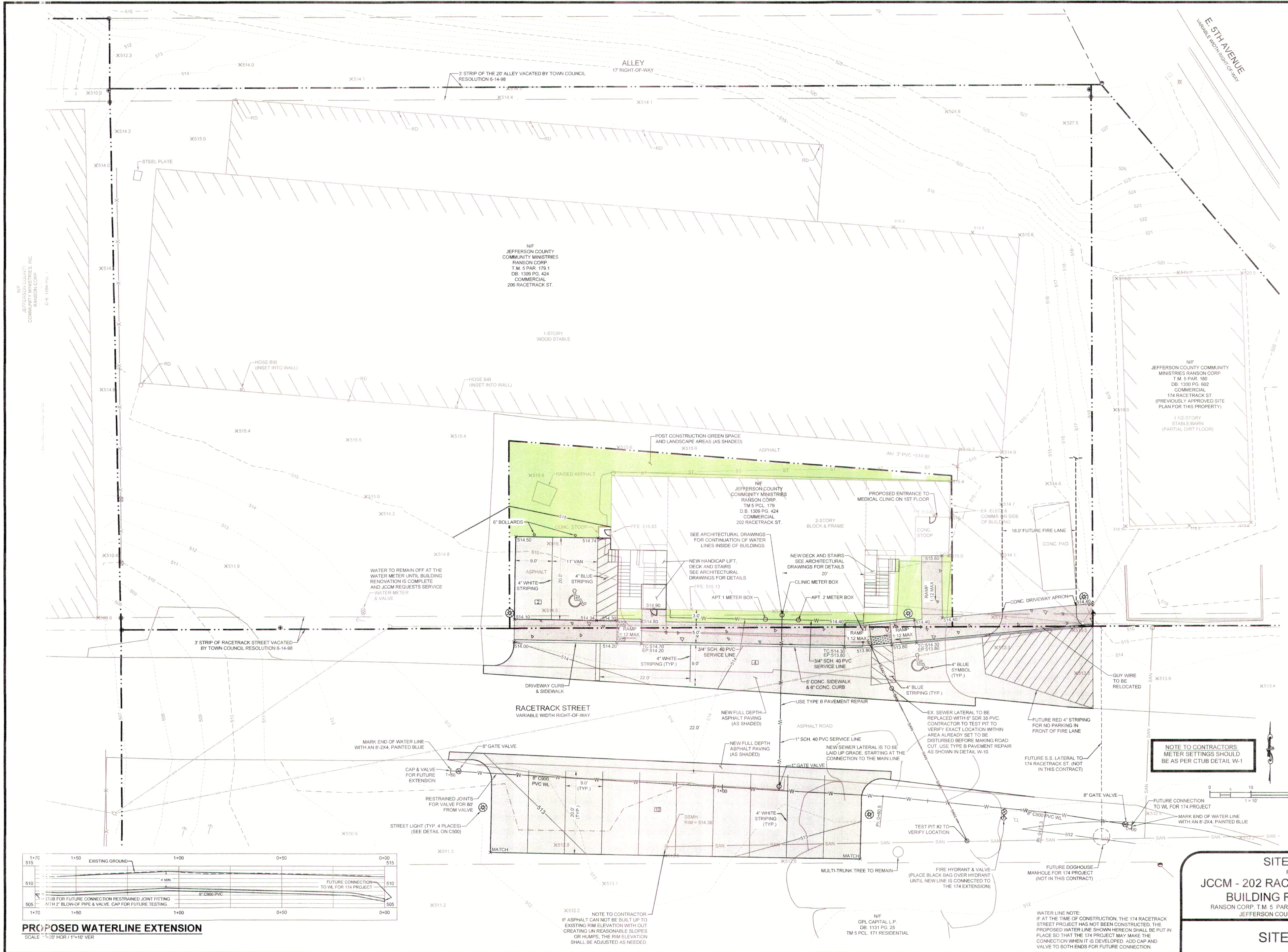

1: 10/16/2024 10:23 AM
 2: 10/16/2024 10:23 AM
 3: 10/16/2024 10:23 AM
 4: 10/16/2024 10:23 AM
 5: 10/16/2024 10:23 AM
 6: 10/16/2024 10:23 AM
 7: 10/16/2024 10:23 AM
 8: 10/16/2024 10:23 AM
 9: 10/16/2024 10:23 AM
 10: 10/16/2024 10:23 AM
 11: 10/16/2024 10:23 AM
 12: 10/16/2024 10:23 AM
 13: 10/16/2024 10:23 AM
 14: 10/16/2024 10:23 AM
 15: 10/16/2024 10:23 AM
 16: 10/16/2024 10:23 AM
 17: 10/16/2024 10:23 AM
 18: 10/16/2024 10:23 AM
 19: 10/16/2024 10:23 AM
 20: 10/16/2024 10:23 AM
 21: 10/16/2024 10:23 AM
 22: 10/16/2024 10:23 AM
 23: 10/16/2024 10:23 AM
 24: 10/16/2024 10:23 AM
 25: 10/16/2024 10:23 AM
 26: 10/16/2024 10:23 AM
 27: 10/16/2024 10:23 AM
 28: 10/16/2024 10:23 AM
 29: 10/16/2024 10:23 AM
 30: 10/16/2024 10:23 AM
 31: 10/16/2024 10:23 AM
 32: 10/16/2024 10:23 AM
 33: 10/16/2024 10:23 AM
 34: 10/16/2024 10:23 AM
 35: 10/16/2024 10:23 AM
 36: 10/16/2024 10:23 AM
 37: 10/16/2024 10:23 AM
 38: 10/16/2024 10:23 AM
 39: 10/16/2024 10:23 AM
 40: 10/16/2024 10:23 AM
 41: 10/16/2024 10:23 AM
 42: 10/16/2024 10:23 AM
 43: 10/16/2024 10:23 AM
 44: 10/16/2024 10:23 AM
 45: 10/16/2024 10:23 AM
 46: 10/16/2024 10:23 AM
 47: 10/16/2024 10:23 AM
 48: 10/16/2024 10:23 AM
 49: 10/16/2024 10:23 AM
 50: 10/16/2024 10:23 AM
 51: 10/16/2024 10:23 AM
 52: 10/16/2024 10:23 AM
 53: 10/16/2024 10:23 AM
 54: 10/16/2024 10:23 AM
 55: 10/16/2024 10:23 AM
 56: 10/16/2024 10:23 AM
 57: 10/16/2024 10:23 AM
 58: 10/16/2024 10:23 AM
 59: 10/16/2024 10:23 AM
 60: 10/16/2024 10:23 AM
 61: 10/16/2024 10:23 AM
 62: 10/16/2024 10:23 AM
 63: 10/16/2024 10:23 AM
 64: 10/16/2024 10:23 AM
 65: 10/16/2024 10:23 AM
 66: 10/16/2024 10:23 AM
 67: 10/16/2024 10:23 AM
 68: 10/16/2024 10:23 AM
 69: 10/16/2024 10:23 AM
 70: 10/16/2024 10:23 AM
 71: 10/16/2024 10:23 AM
 72: 10/16/2024 10:23 AM
 73: 10/16/2024 10:23 AM
 74: 10/16/2024 10:23 AM
 75: 10/16/2024 10:23 AM
 76: 10/16/2024 10:23 AM
 77: 10/16/2024 10:23 AM
 78: 10/16/2024 10:23 AM
 79: 10/16/2024 10:23 AM
 80: 10/16/2024 10:23 AM
 81: 10/16/2024 10:23 AM
 82: 10/16/2024 10:23 AM
 83: 10/16/2024 10:23 AM
 84: 10/16/2024 10:23 AM
 85: 10/16/2024 10:23 AM
 86: 10/16/2024 10:23 AM
 87: 10/16/2024 10:23 AM
 88: 10/16/2024 10:23 AM
 89: 10/16/2024 10:23 AM
 90: 10/16/2024 10:23 AM
 91: 10/16/2024 10:23 AM
 92: 10/16/2024 10:23 AM
 93: 10/16/2024 10:23 AM
 94: 10/16/2024 10:23 AM
 95: 10/16/2024 10:23 AM
 96: 10/16/2024 10:23 AM
 97: 10/16/2024 10:23 AM
 98: 10/16/2024 10:23 AM
 99: 10/16/2024 10:23 AM
 100: 10/16/2024 10:23 AM
 101: 10/16/2024 10:23 AM
 102: 10/16/2024 10:23 AM
 103: 10/16/2024 10:23 AM
 104: 10/16/2024 10:23 AM
 105: 10/16/2024 10:23 AM
 106: 10/16/2024 10:23 AM
 107: 10/16/2024 10:23 AM
 108: 10/16/2024 10:23 AM
 109: 10/16/2024 10:23 AM
 110: 10/16/2024 10:23 AM
 111: 10/16/2024 10:23 AM
 112: 10/16/2024 10:23 AM
 113: 10/16/2024 10:23 AM
 114: 10/16/2024 10:23 AM
 115: 10/16/2024 10:23 AM
 116: 10/16/2024 10:23 AM
 117: 10/16/2024 10:23 AM
 118: 10/16/2024 10:23 AM
 119: 10/16/2024 10:23 AM
 120: 10/16/2024 10:23 AM
 121: 10/16/2024 10:23 AM
 122: 10/16/2024 10:23 AM
 123: 10/16/2024 10:23 AM
 124: 10/16/2024 10:23 AM
 125: 10/16/2024 10:23 AM
 126: 10/16/2024 10:23 AM
 127: 10/16/2024 10:23 AM
 128: 10/16/2024 10:23 AM
 129: 10/16/2024 10:23 AM
 130: 10/16/2024 10:23 AM
 131: 10/16/2024 10:23 AM
 132: 10/16/2024 10:23 AM
 133: 10/16/2024 10:23 AM
 134: 10/16/2024 10:23 AM
 135: 10/16/2024 10:23 AM
 136: 10/16/2024 10:23 AM
 137: 10/16/2024 10:23 AM
 138: 10/16/2024 10:23 AM
 139: 10/16/2024 10:23 AM
 140: 10/16/2024 10:23 AM
 141: 10/16/2024 10:23 AM
 142: 10/16/2024 10:23 AM
 143: 10/16/2024 10:23 AM
 144: 10/16/2024 10:23 AM
 145: 10/16/2024 10:23 AM
 146: 10/16/2024 10:23 AM
 147: 10/16/2024 10:23 AM
 148: 10/16/2024 10:23 AM
 149: 10/16/2024 10:23 AM
 150: 10/16/2024 10:23 AM
 151: 10/16/2024 10:23 AM
 152: 10/16/2024 10:23 AM
 153: 10/16/2024 10:23 AM
 154: 10/16/2024 10:23 AM
 155: 10/16/2024 10:23 AM
 156: 10/16/2024 10:23 AM
 157: 10/16/2024 10:23 AM
 158: 10/16/2024 10:23 AM
 159: 10/16/2024 10:23 AM
 160: 10/16/2024 10:23 AM
 161: 10/16/2024 10:23 AM
 162: 10/16/2024 10:23 AM
 163: 10/16/2024 10:23 AM
 164: 10/16/2024 10:23 AM
 165: 10/16/2024 10:23 AM
 166: 10/16/2024 10:23 AM
 167: 10/16/2024 10:23 AM
 168: 10/16/2024 10:23 AM
 169: 10/16/2024 10:23 AM
 170: 10/16/2024 10:23 AM
 171: 10/16/2024 10:23 AM
 172: 10/16/2024 10:23 AM
 173: 10/16/2024 10:23 AM
 174: 10/16/2024 10:23 AM
 175: 10/16/2024 10:23 AM
 176: 10/16/2024 10:23 AM
 177: 10/16/2024 10:23 AM
 178: 10/16/2024 10:23 AM
 179: 10/16/2024 10:23 AM
 180: 10/16/2024 10:23 AM
 181: 10/16/2024 10:23 AM
 182: 10/16/2024 10:23 AM
 183: 10/16/2024 10:23 AM
 184: 10/16/2024 10:23 AM
 185: 10/16/2024 10:23 AM
 186: 10/16/2024 10:23 AM
 187: 10/16/2024 10:23 AM
 188: 10/16/2024 10:23 AM
 189: 10/16/2024 10:23 AM
 190: 10/16/2024 10:23 AM
 191: 10/16/2024 10:23 AM
 192: 10/16/2024 10:23 AM
 193: 10/16/2024 10:23 AM
 194: 10/16/2024 10:23 AM
 195: 10/16/2024 10:23 AM
 196: 10/16/2024 10:23 AM
 197: 10/16/2024 10:23 AM
 198: 10/16/2024 10:23 AM
 199: 10/16/2024 10:23 AM
 200: 10/16/2024 10:23 AM
 201: 10/16/2024 10:23 AM
 202: 10/16/2024 10:23 AM
 203: 10/16/2024 10:23 AM
 204: 10/16/2024 10:23 AM
 205: 10/16/2024 10:23 AM
 206: 10/16/2024 10:23 AM
 207: 10/16/2024 10:23 AM
 208: 10/16/2024 10:23 AM
 209: 10/16/2024 10:23 AM
 210: 10/16/2024 10:23 AM
 211: 10/16/2024 10:23 AM
 212: 10/16/2024 10:23 AM
 213: 10/16/2024 10:23 AM
 214: 10/16/2024 10:23 AM
 215: 10/16/2024 10:23 AM
 216: 10/16/2024 10:23 AM
 217: 10/16/2024 10:23 AM
 218: 10/16/2024 10:23 AM
 219: 10/16/2024 10:23 AM
 220: 10/16/2024 10:23 AM
 221: 10/16/2024 10:23 AM
 222: 10/16/2024 10:23 AM
 223: 10/16/2024 10:23 AM
 224: 10/16/2024 10:23 AM
 225: 10/16/2024 10:23 AM
 226: 10/16/2024 10:23 AM
 227: 10/16/2024 10:23 AM
 228: 10/16/2024 10:23 AM
 229: 10/16/2024 10:23 AM
 230: 10/16/2024 10:23 AM
 231: 10/16/2024 10:23 AM
 232: 10/16/2024 10:23 AM
 233: 10/16/2024 10:23 AM
 234: 10/16/2024 10:23 AM
 235: 10/16/2024 10:23 AM
 236: 10/16/2024 10:23 AM
 237: 10/16/2024 10:23 AM
 238: 10/16/2024 10:23 AM
 239: 10/16/2024 10:23 AM
 240: 10/16/2024 10:23 AM
 241: 10/16/2024 10:23 AM
 242: 10/16/2024 10:23 AM
 243: 10/16/2024 10:23 AM
 244: 10/16/2024 10:23 AM
 245: 10/16/2024 10:23 AM
 246: 10/16/2024 10:23 AM
 247: 10/16/2024 10:23 AM
 248: 10/16/2024 10:23 AM
 249: 10/16/2024 10:23 AM
 250: 10/16/2024 10:23 AM
 251: 10/16/2024 10:23 AM
 252: 10/16/2024 10:23 AM
 253: 10/16/2024 10:23 AM
 254: 10/16/2024 10:23 AM
 255: 10/16/2024 10:23 AM
 256: 10/16/2024 10:23 AM
 257: 10/16/2024 10:23 AM
 258: 10/16/2024 10:23 AM
 259: 10/16/2024 10:23 AM
 260: 10/16/2024 10:23 AM
 261: 10/16/2024 10:23 AM
 262: 10/16/2024 10:23 AM
 263: 10/16/2024 10:23 AM
 264: 10/16/2024 10:23 AM
 265: 10/16/2024 10:23 AM
 266: 10/16/2024 10:23 AM
 267: 10/16/2024 10:23 AM
 268: 10/16/2024 10:23 AM
 269: 10/16/2024 10:23 AM
 270: 10/16/2024 10:23 AM
 271: 10/16/2024 10:23 AM
 272: 10/16/2024 10:23 AM
 273: 10/16/2024 10:23 AM
 274: 10/16/2024 10:23 AM
 275: 10/16/2024 10:23 AM
 276: 10/16/2024 10:23 AM
 277: 10/16/2024 10:23 AM
 278: 10/16/2024 10:23 AM
 279: 10/16/2024 10:23 AM
 280: 10/16/2024 10:23 AM
 281: 10/16/2024 10:23 AM
 282: 10/16/2024 10:23 AM
 283: 10/16/2024 10:23 AM
 284: 10/16/2024 10:23 AM
 285: 10/16/2024 10:23 AM
 286: 10/16/2024 10:23 AM
 287: 10/16/2024 10:23 AM
 288: 10/16/2024 10:23 AM
 289: 10/16/2024 10:23 AM
 290: 10/16/2024 10:23 AM
 291: 10/16/2024 10:23 AM
 292: 10/16/2024 10:23 AM
 293: 10/16/2024 10:23 AM
 294: 10/16/2024 10:23 AM
 295: 10/16/2024 10:23 AM
 296: 10/16/2024 10:23 AM
 297: 10/16/2024 10:23 AM
 298: 10/16/2024 10:23 AM
 299: 10/16/2024 10:23 AM
 300: 10/16/2024 10:23 AM
 301: 10/16/2024 10:23 AM
 302: 10/16/2024 10:23 AM
 303: 10/16/2024 10:23 AM
 304: 10/16/2024 10:23 AM
 305: 10/16/2024 10:23 AM
 306: 10/16/2024 10:23 AM
 307: 10/16/2024 10:23 AM
 308: 10/16/2024 10:23 AM
 309: 10/16/2024 10:23 AM
 310: 10/16/2024 10:23 AM
 311: 10/16/2024 10:23 AM
 312: 10/16/2024 10:23 AM
 313: 10/16/2024 10:23 AM
 314: 10/16/2024 10:23 AM
 315: 10/16/2024 10:23 AM
 316: 10/16/2024 10:23 AM
 317: 10/16/2024 10:23 AM
 318: 10/16/2024 10:23 AM
 319: 10/16/2024 10:23 AM
 320: 10/16/2024 10:23 AM
 321: 10/16/2024 10:23 AM
 322: 10/16/2024 10:23 AM
 323: 10/16/2024 10:23 AM
 324: 10/16/2024 10:23 AM
 325: 10/16/2024 10:23 AM
 326: 10/16/2024 10:23 AM
 327: 10/16/2024 10:23 AM
 328: 10/16/2024 10:23 AM
 329: 10/16/2024 10:23 AM
 330: 10/16/2024 10:23 AM
 331: 10/16/2024 10:23 AM
 332: 10/16/2024 10:23 AM
 333: 10/16/2024 10:23 AM
 334: 10/16/2024 10:23 AM
 335: 10/16/2024 10:23 AM
 336: 10/16/2024 10:23 AM
 337: 10/16/2024 10:23 AM
 338: 10/16/2024 10:23 AM
 339: 10/16/2024 10:23 AM
 340: 10/16/2024 10:23 AM
 341: 10/16/2024 10:23 AM
 342: 10/16/2024 10:23 AM
 343: 10/16/2024 10:23 AM
 344: 10/16/2024 10:23 AM
 345: 10/16/2024 10:23 AM
 346: 10/16/2024 10:23 AM
 347: 10/16/2024 10:23 AM
 348: 10/16/2024 10:23 AM
 349: 10/16/2024 10:23 AM
 350: 10/16/2024 10:23 AM
 351: 10/16/2024 10:23 AM
 352: 10/16/2024 10:23 AM
 353: 10/16/2024 10:23 AM
 354: 10/16/2024 10:23 AM
 355: 10/16/2024 10:23 AM
 356: 10/16/2024 10:23 AM
 357: 10/16/2024 10:23 AM
 358: 10/16/2024 10:23 AM
 359: 10/16/2024 10:23 AM
 360: 10/16/2024 10:23 AM
 361: 10/16/2024 10:23 AM
 362: 10/16/2024 10:23 AM
 363: 10/16/2024 10:23 AM
 364: 10/16/2024 10:23 AM
 365: 10/16/2024 10:23 AM
 366: 10/16/2024 10:23 AM
 367: 10/16/2024 10:23 AM
 368: 10/16/2024 10:23 AM
 369: 10/16/2024 10:23 AM
 370: 10/16/2024 10:23 AM
 371: 10/16/2024 10:23 AM
 372: 10/16/2024 10:23 AM
 373: 10/16/2024 10:23 AM
 374: 10/16/2024 10:23 AM
 375: 10/16/2024 10:23 AM
 376: 10/16/2024 10:23 AM
 377: 10/16/2024 10:23 AM
 378: 10/16/2024 10:23 AM
 379: 10/16/2024 10:23 AM
 380: 10/16/2024 10:23 AM
 381: 10/16/2024 10:23 AM
 382: 10/16/2024 10:23 AM
 383: 10/16/2024 10:23 AM
 384: 10/16/2024 10:23 AM
 385: 10/16/2024 10:23 AM
 386: 10/16/2024 10:23 AM
 387: 10/16/2024 10:23 AM
 388: 10/16/2024 10:23 AM
 389: 10/16/2024 10:23 AM
 390: 10/16/2024 10:23 AM
 391: 10/16/2024 10:23 AM
 392: 10/16/2024 10:23 AM
 393: 10/16/2024 10:23 AM
 394: 10/16/2024 10:23 AM
 395: 10/16/2024 10:23 AM
 396: 10/16/2024 10:23 AM
 397: 10/16/2024 10:23 AM
 398: 10/16/2024 10:23 AM
 399: 10/16/2024 10:23 AM
 400: 10/16/2024 10:23 AM
 401: 10/16/2024 10:23 AM
 402: 10/16/2024 10:23 AM
 403: 10/16/2024 10:23 AM
 404: 10/16/2024 10:23 AM
 405: 10/16/2024 10:23 AM
 406: 10/16/2024 10:23 AM
 407: 10/16/2024 10:23 AM
 408: 10/16/2024 10:23 AM
 409: 10/16/2024 10:23 AM
 410: 10/16/2024 10:23 AM
 411: 10/16/2024 10:23 AM
 412: 10/16/2024 10:23 AM



OWNER/DEVELOPER:
JEFFERSON COUNTY
COMMUNITY MINISTRIES, INC.
ADDRESS:
238 W WASHINGTON ST.
CHARLES TOWN, WV, 25414
PHONE:
571-213-4651
ATTN:
KEITH LOWRY

REVISIONS		
No.	ITEM	DATE
1	CITY REVIEW COMMENTS	11/12/2024
2	CTUB REVIEW COMMENTS	01/13/2024
3	CTUB REVIEW COMMENTS	02/29/2024
4	CITY REVIEW COMMENTS	02/27/2024

PROJ. NO: 2309065.00
DATE: 7/11/2024
SHEET NO.:

C500
COPYRIGHT 2024 ALPHA ASSOCIATES, INC.
ALL RIGHTS RESERVED.

SITE PLAN FOR
JCCM - 202 RACETRACK STREET
BUILDING RENOVATION
RANSON CORP, T.M. 5 PARS. 179 & 179.1 D.B. 1309 Pg. 424
JEFFERSON COUNTY, WEST VIRGINIA

DETAILS

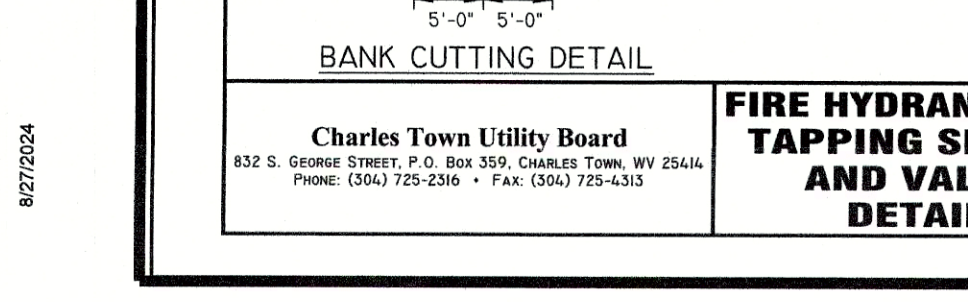
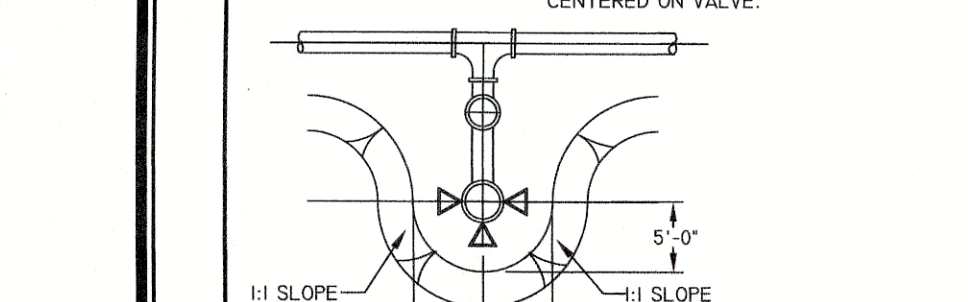
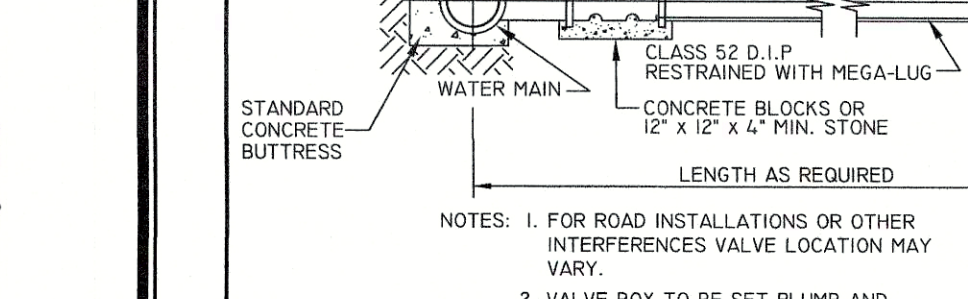
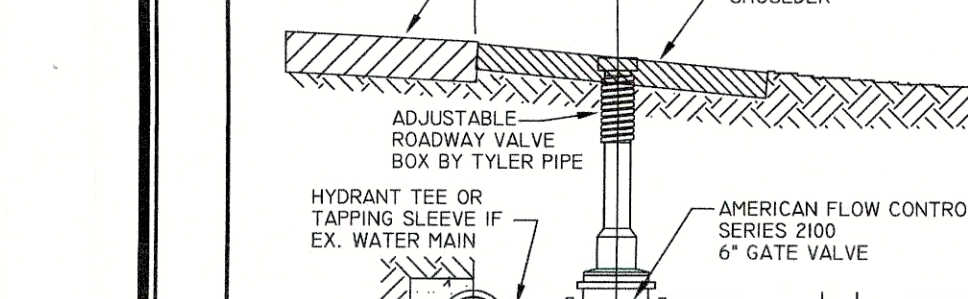
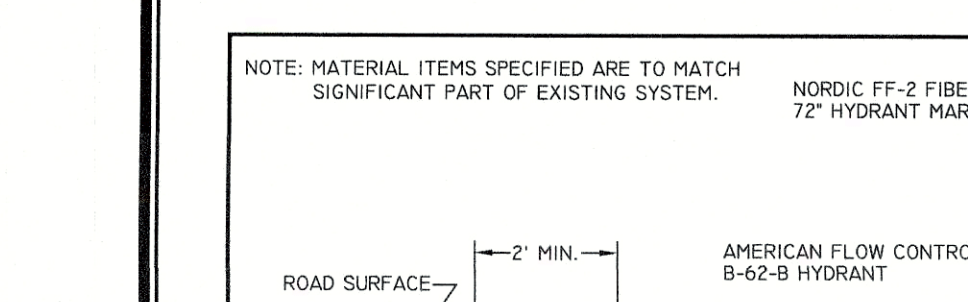
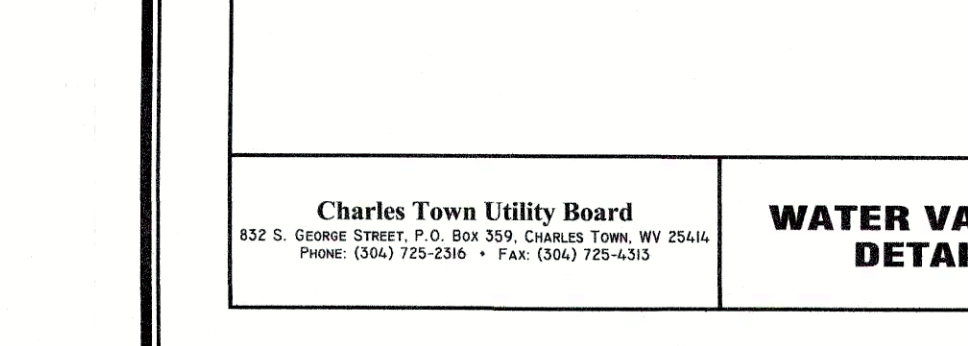
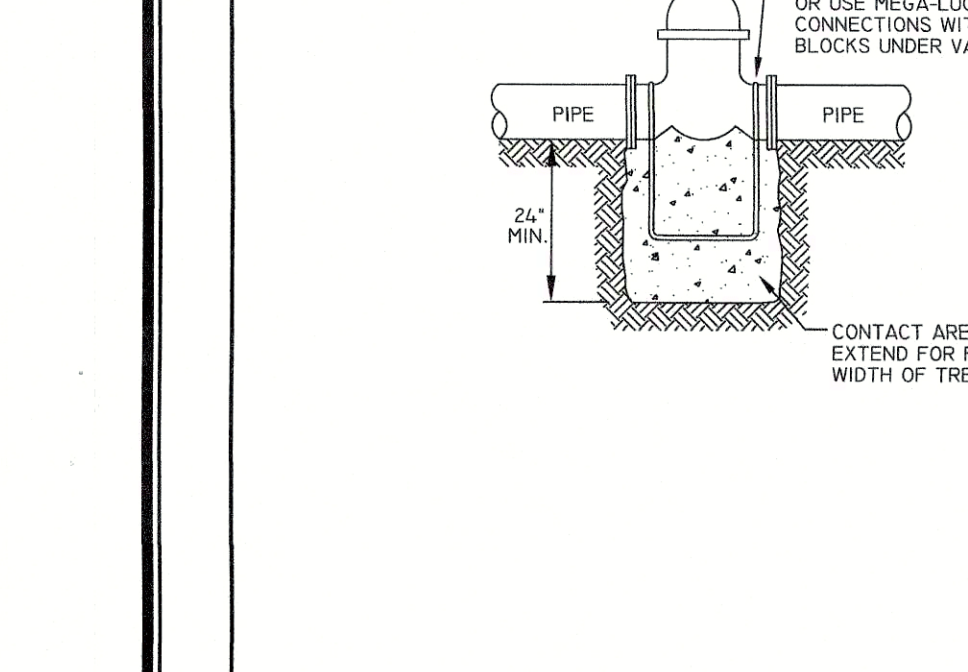
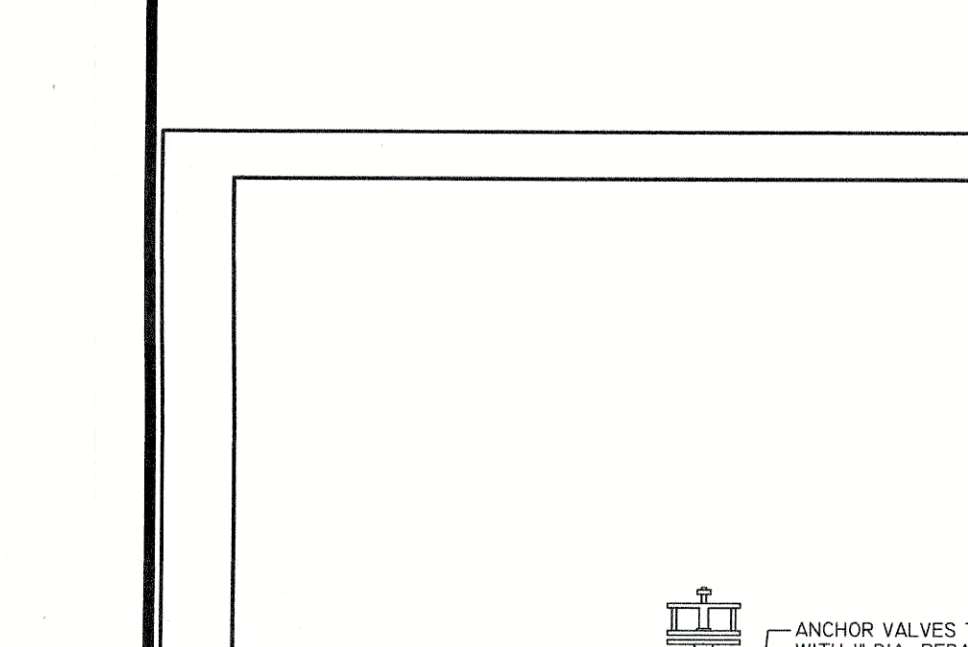
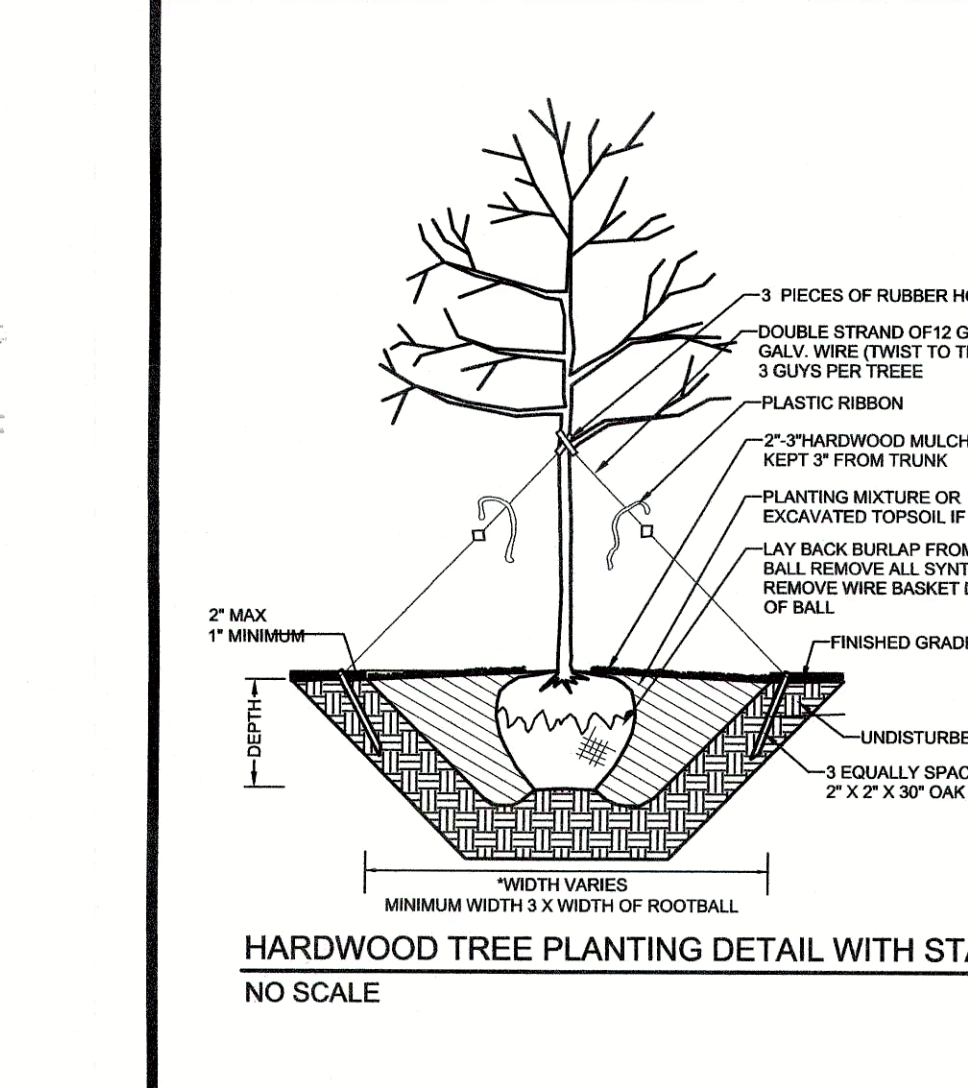
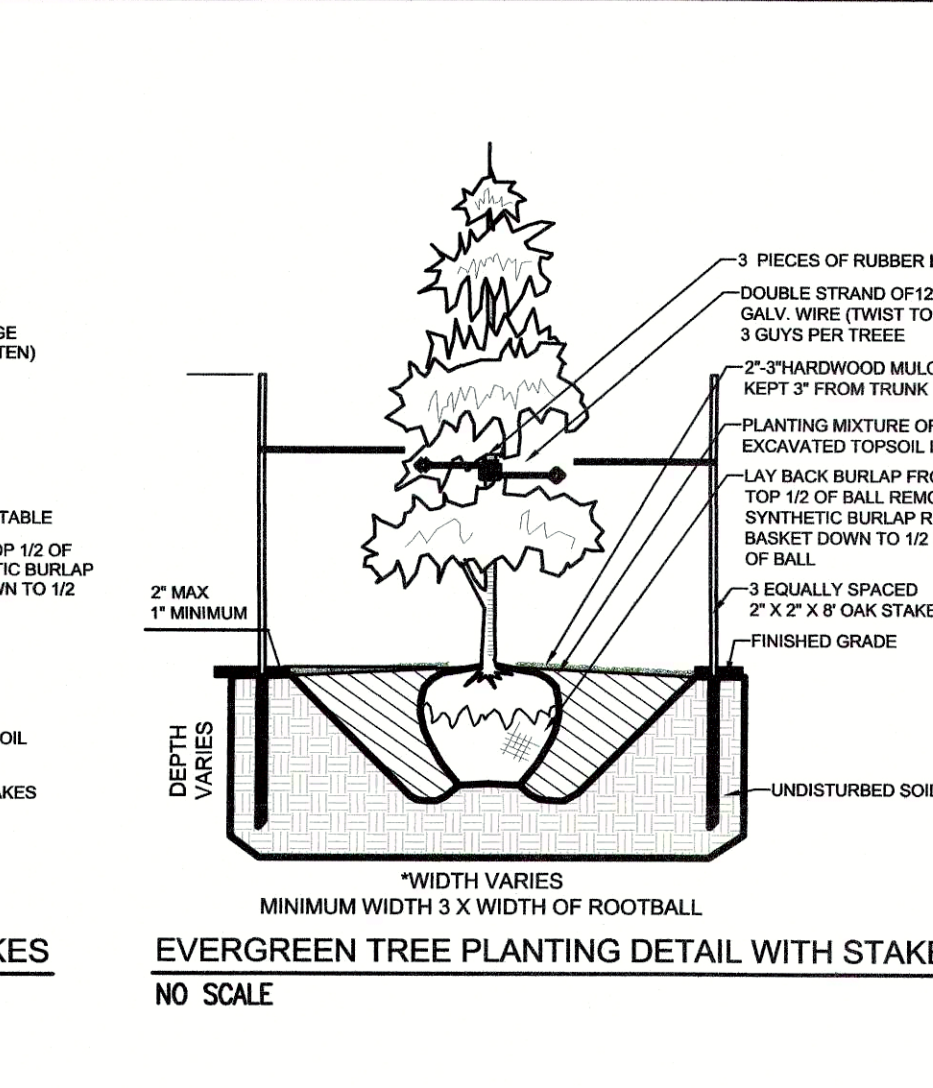
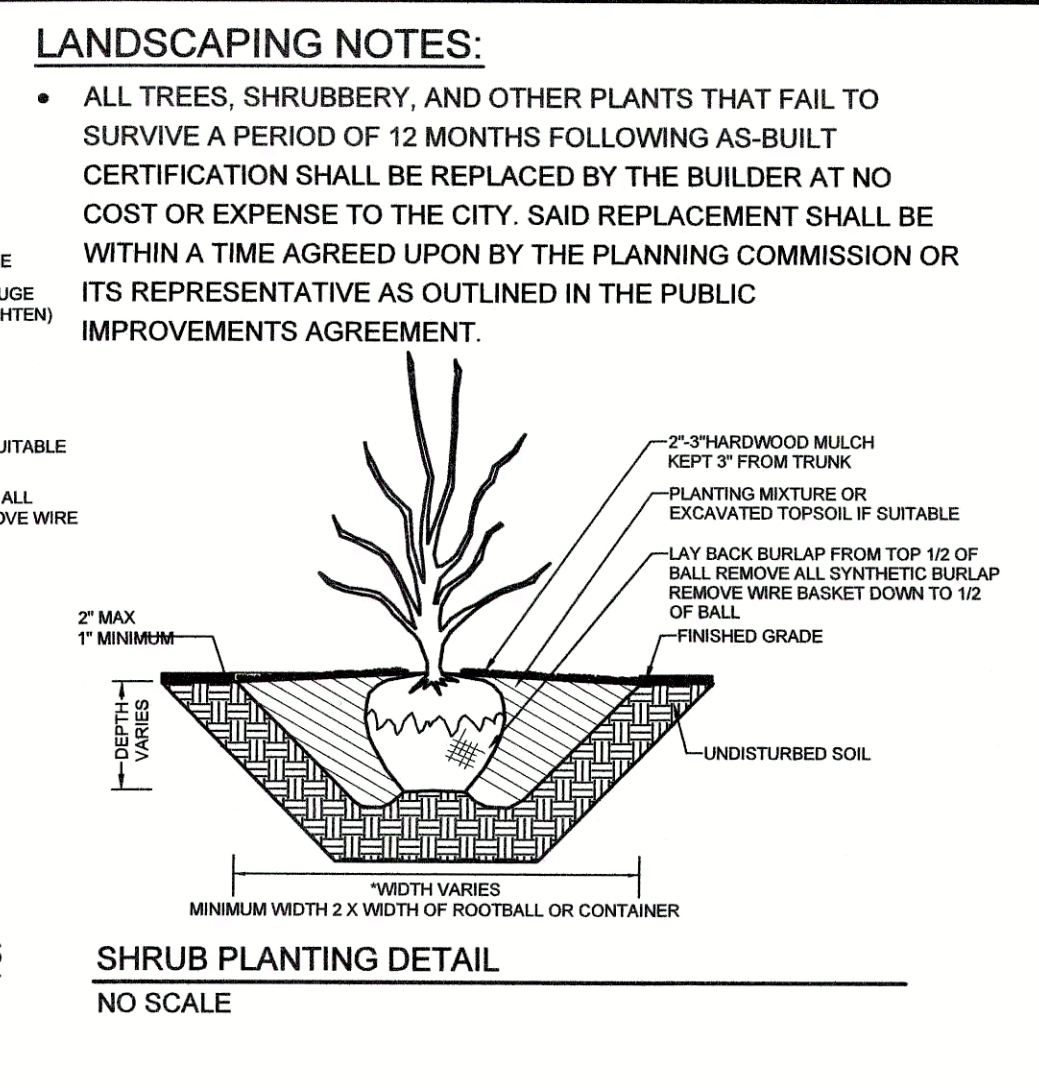
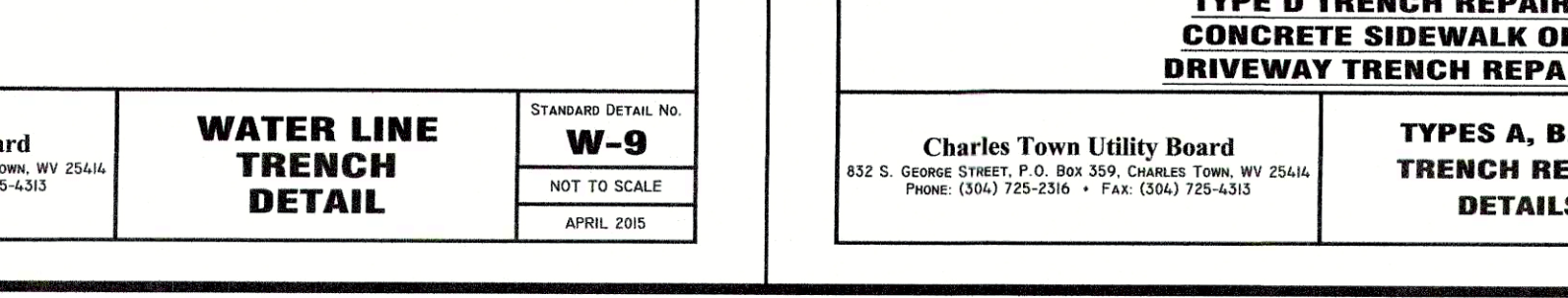
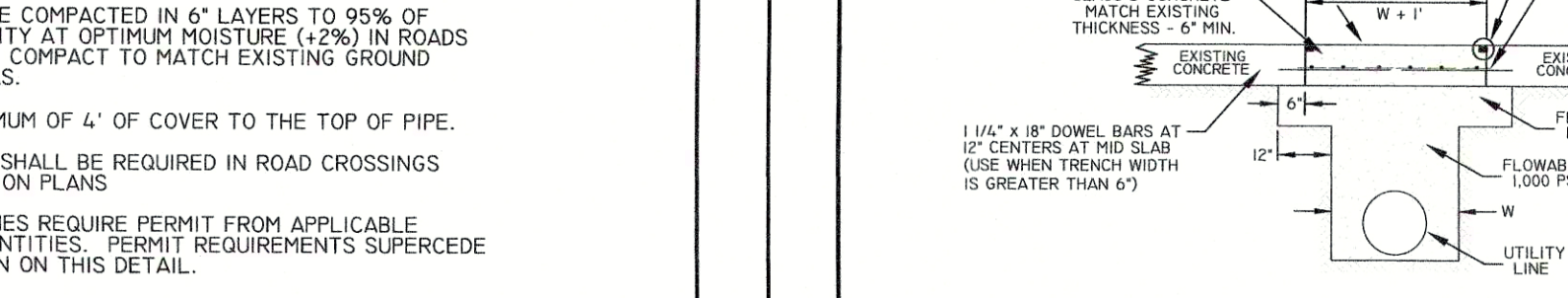
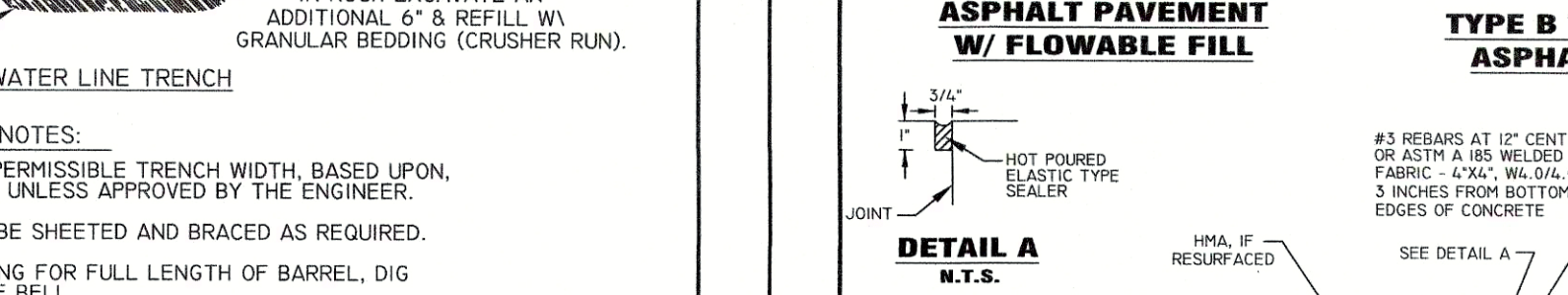
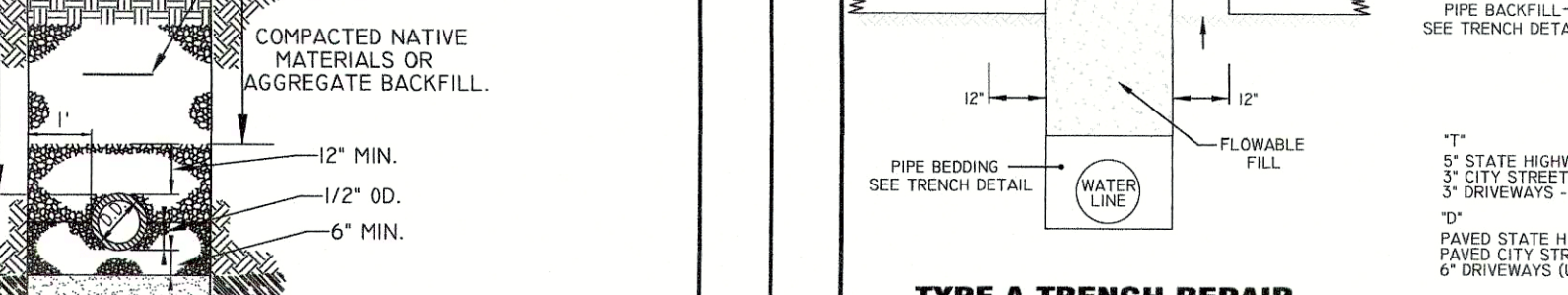
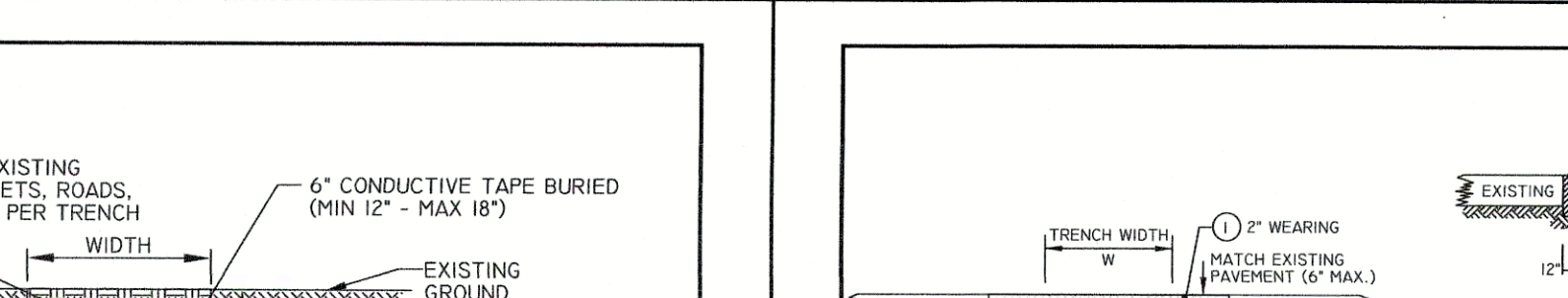
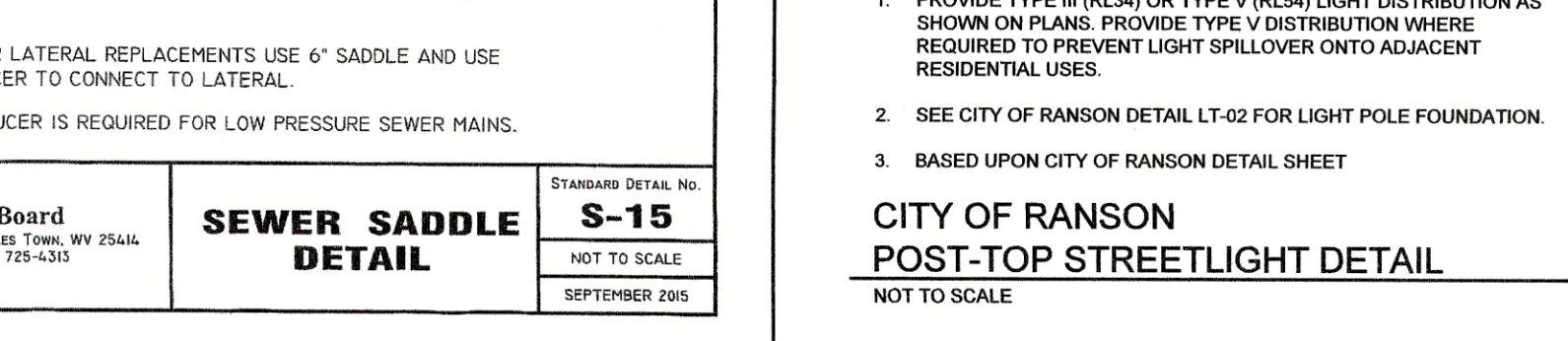
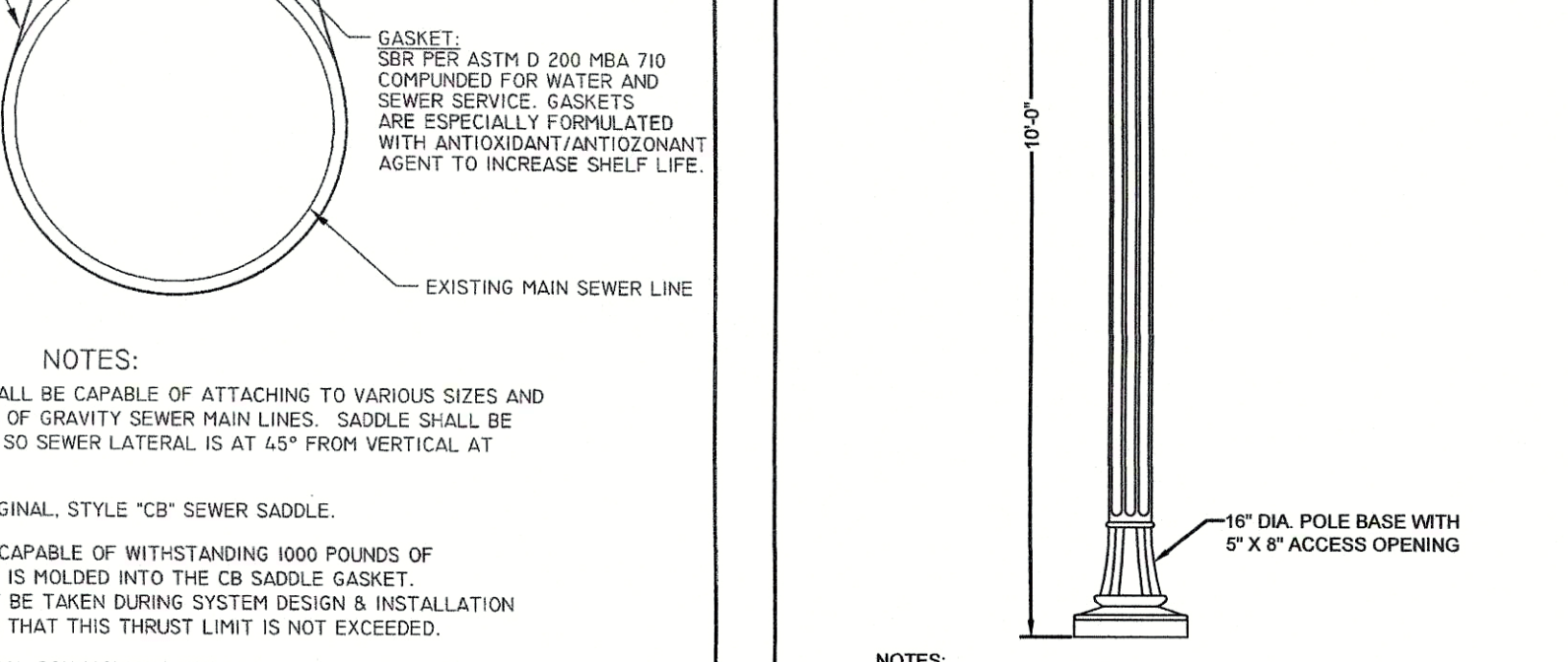
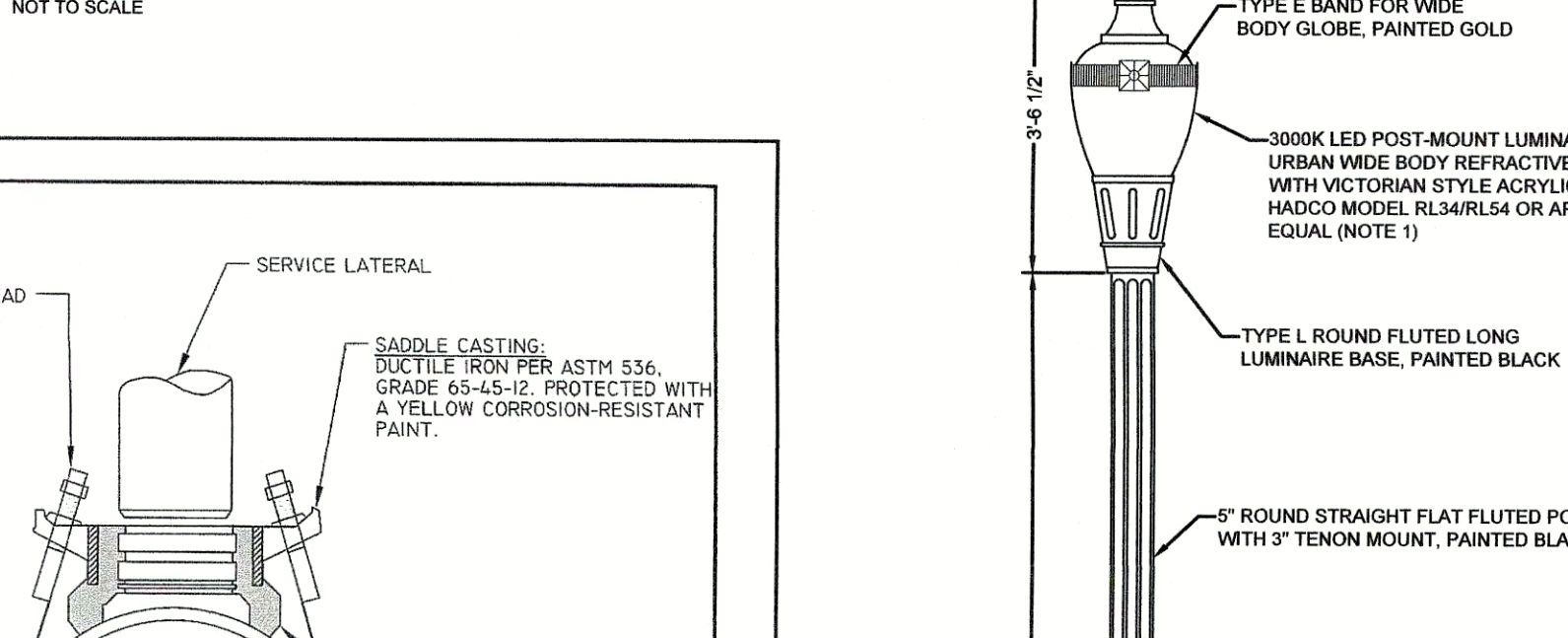
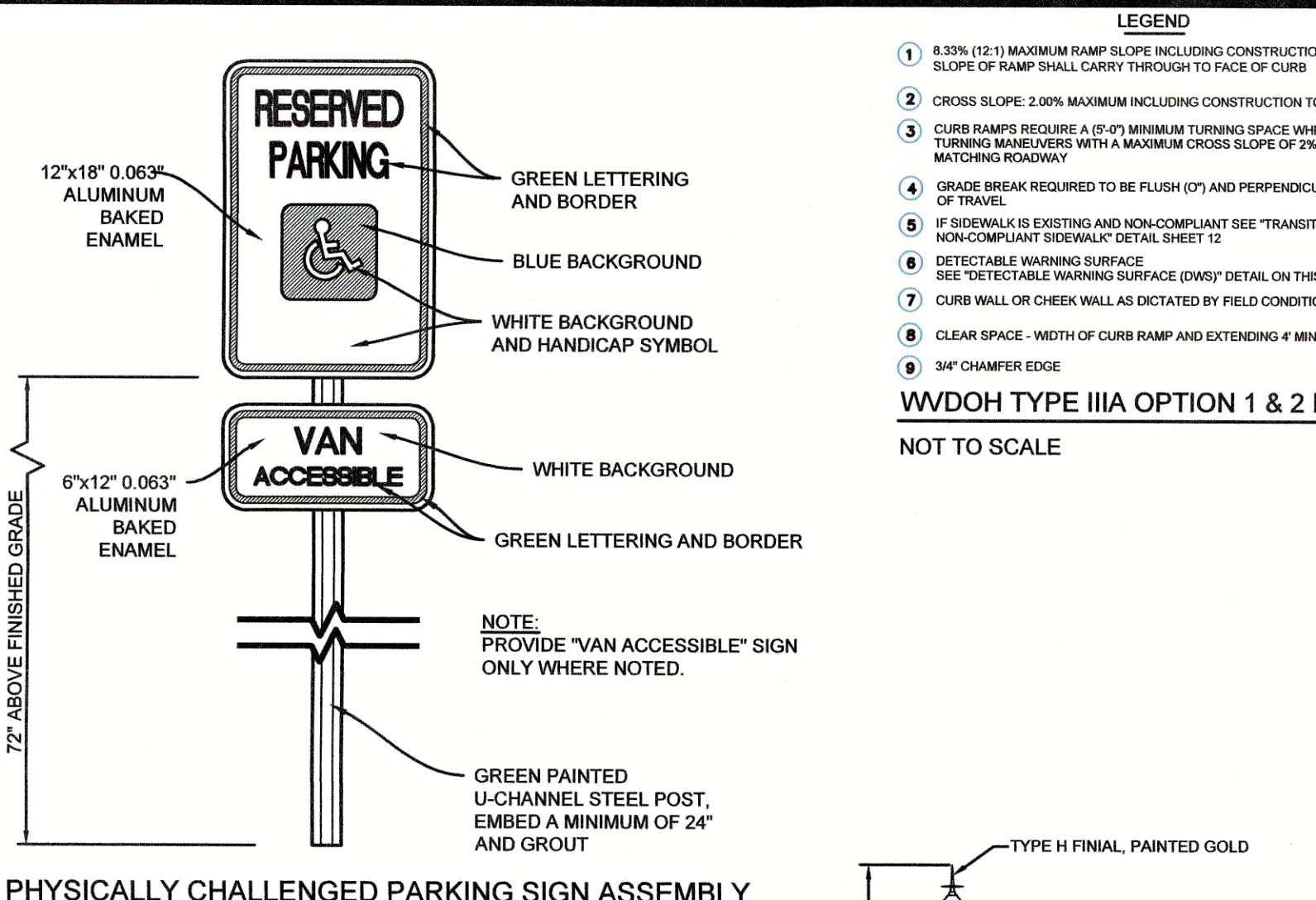
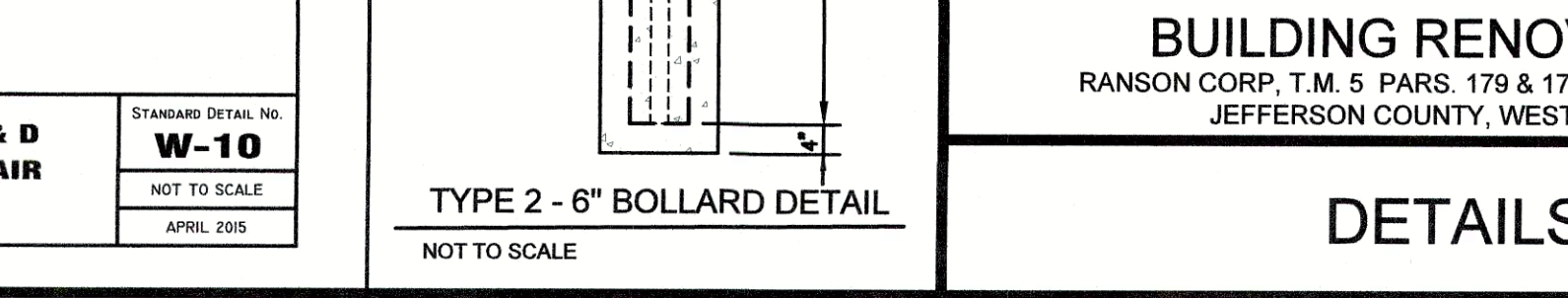
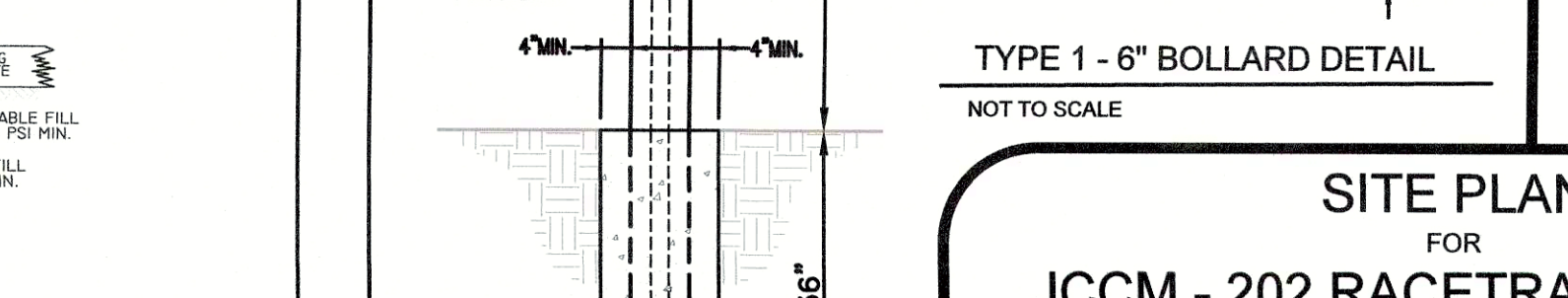
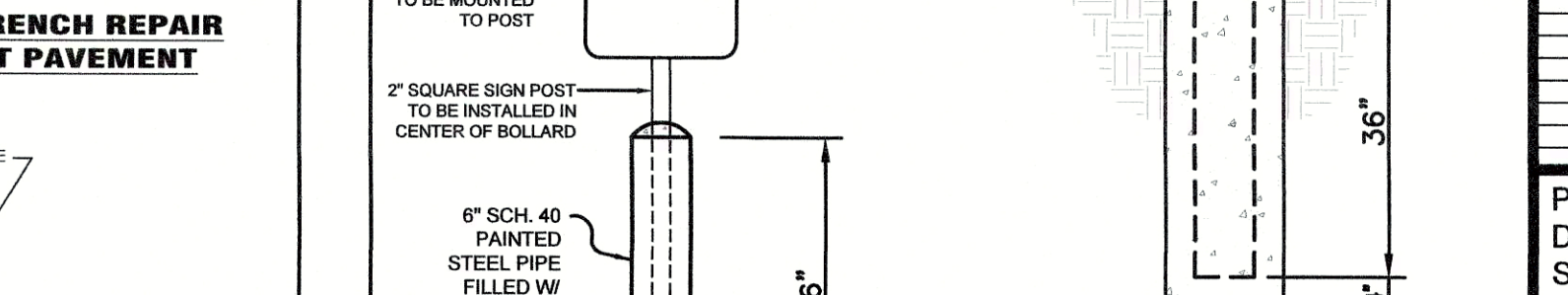
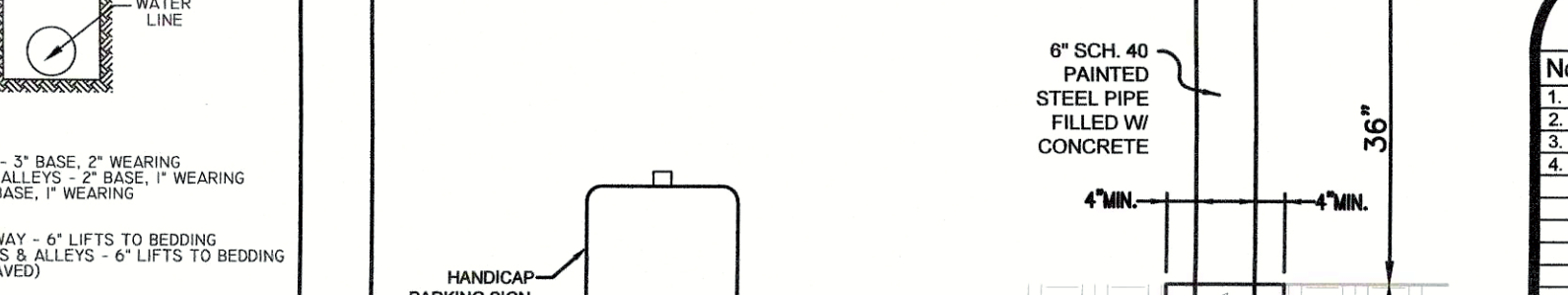
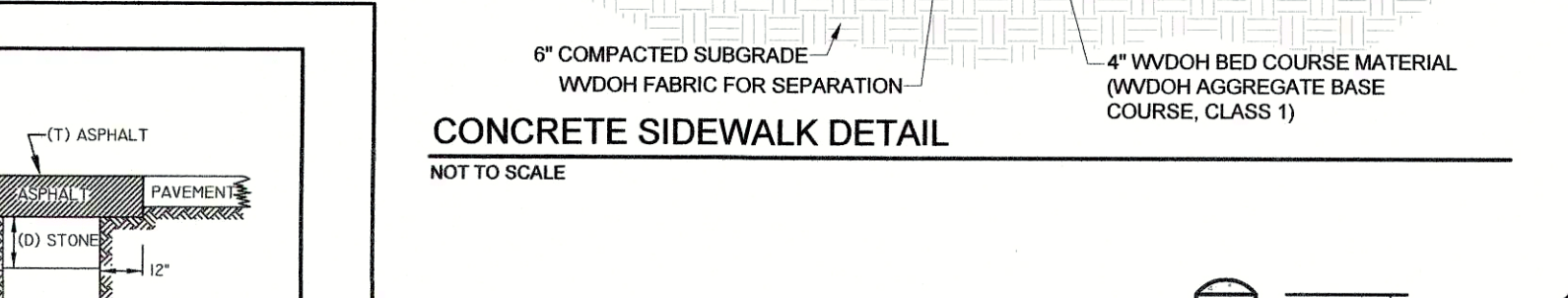
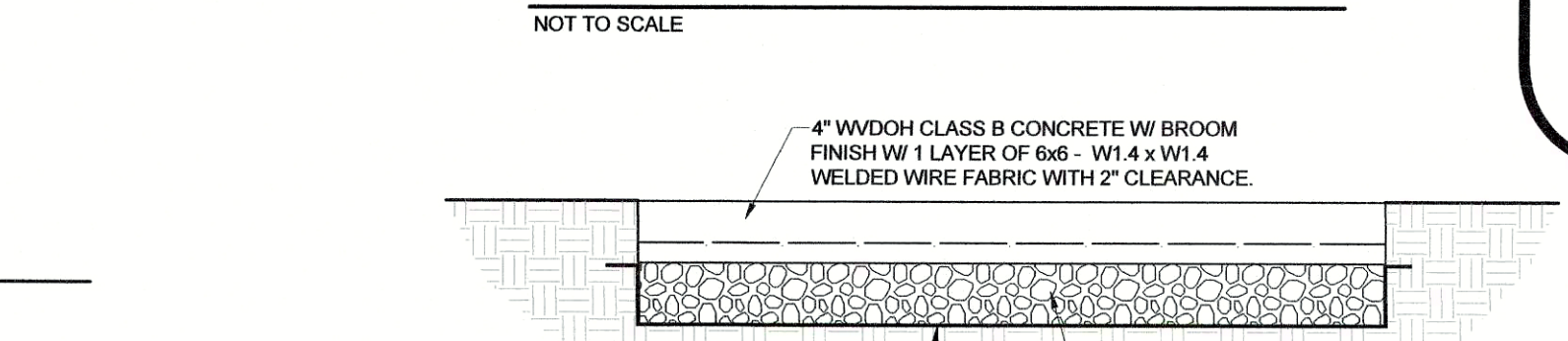
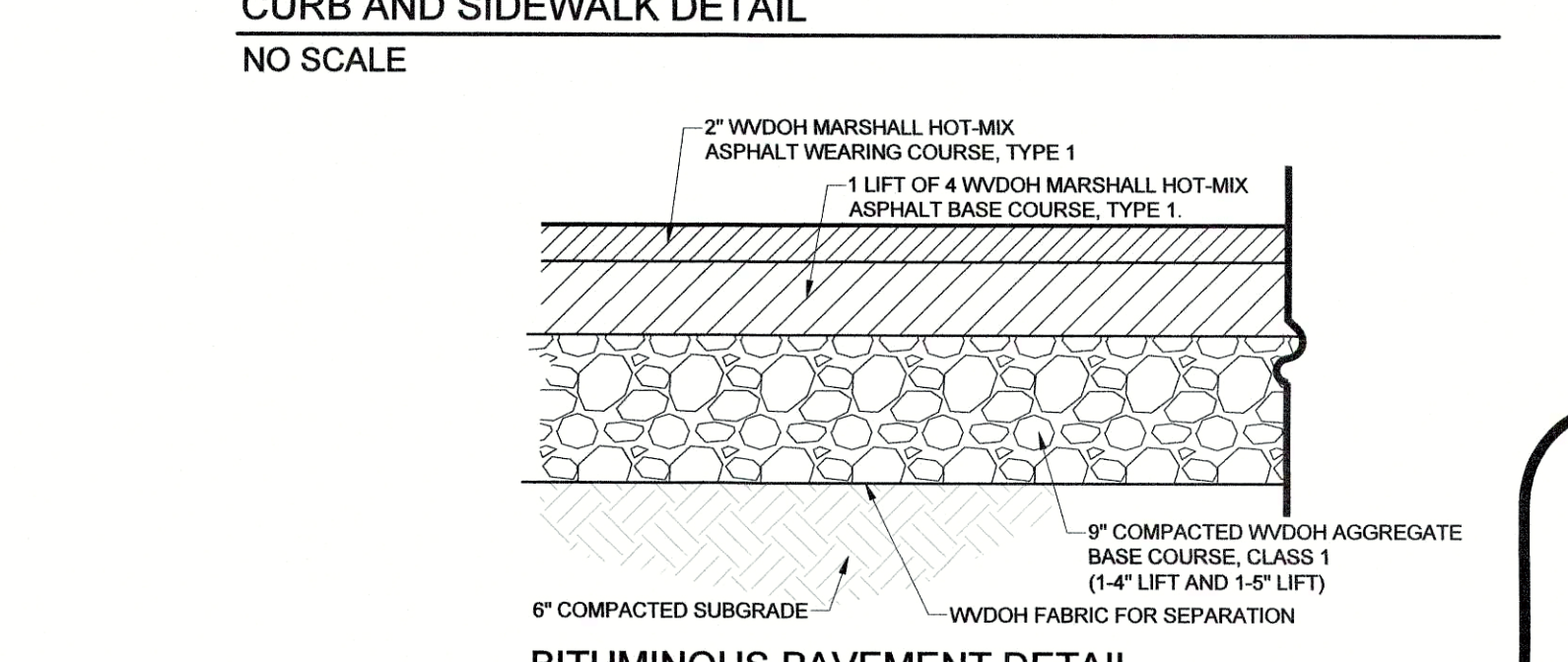
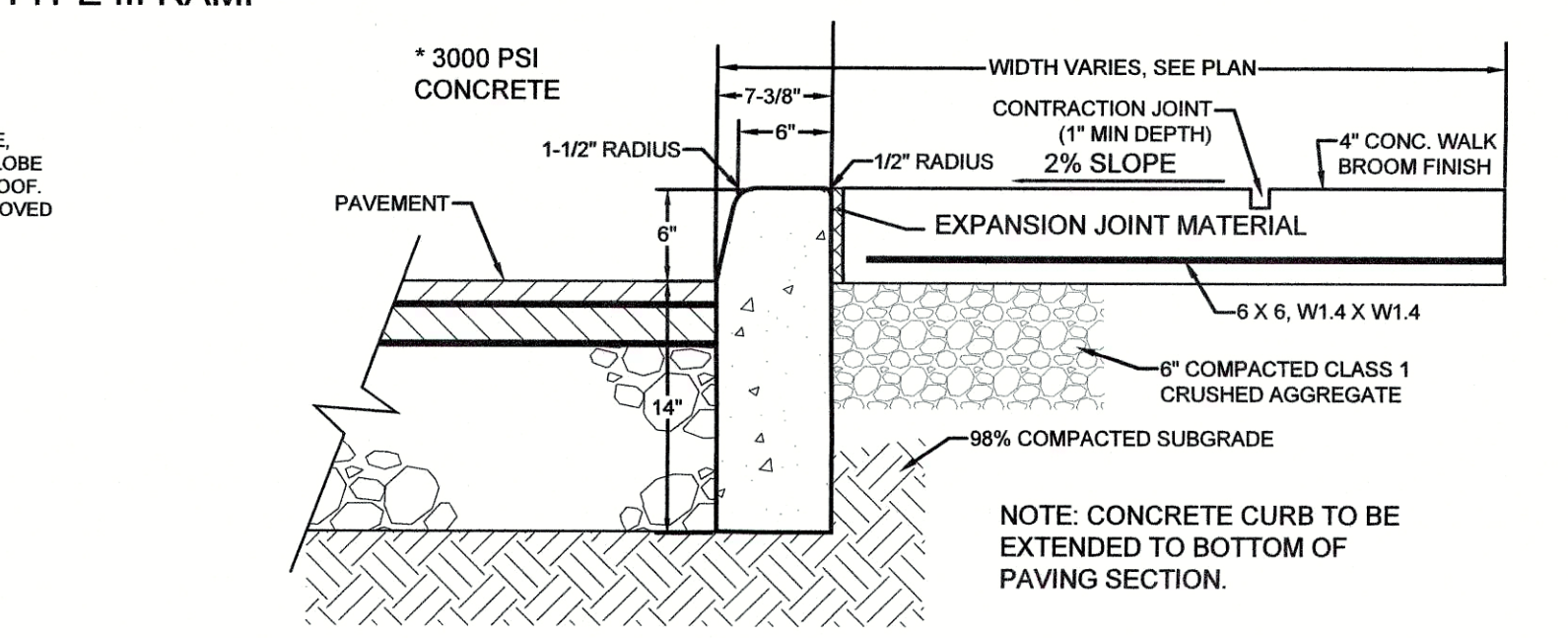
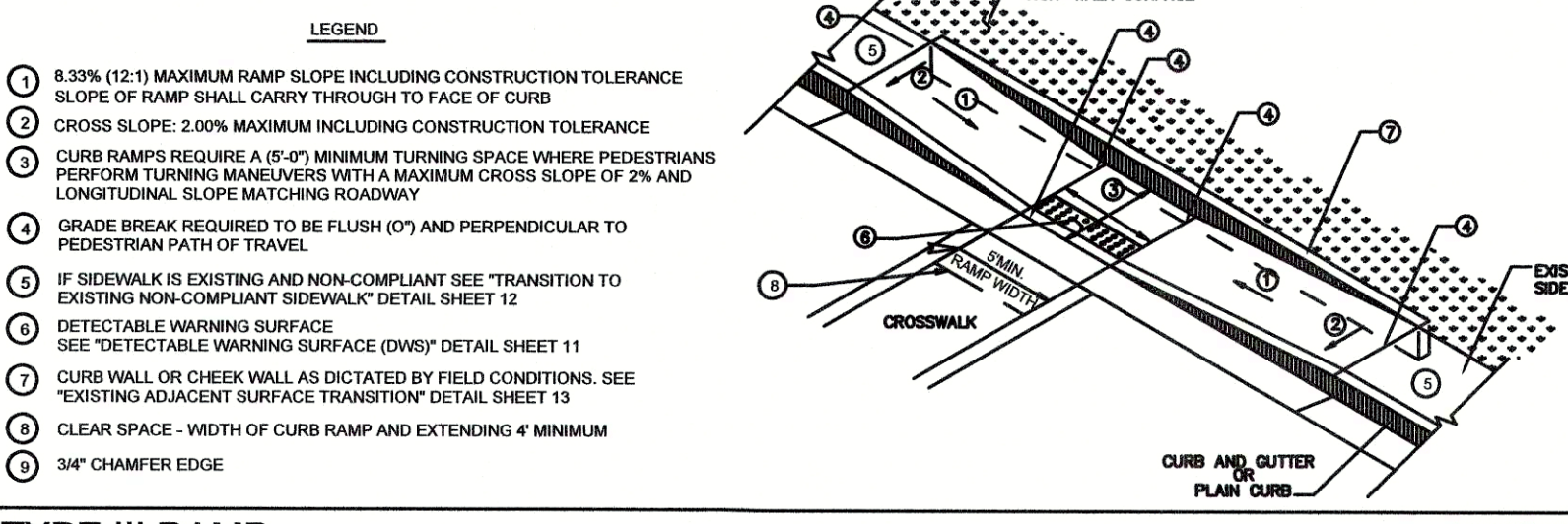
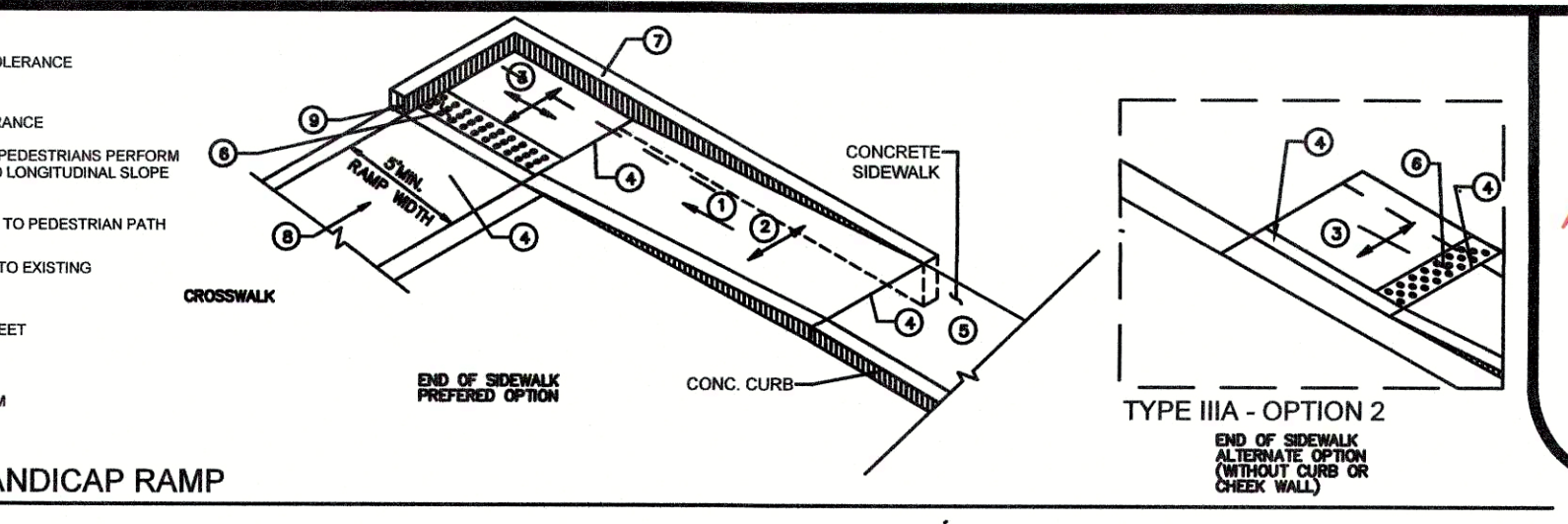

LANDSCAPING NOTES:

- ALL TREES, SHRUBBERY, AND OTHER PLANTS THAT FAIL TO SURVIVE A PERIOD OF 12 MONTHS FOLLOWING AS-BUILT CERTIFICATION SHALL BE REPLACED BY THE BUILDER AT NO COST OR EXPENSE TO THE CITY. SAID REPLACEMENT SHALL BE WITHIN A TIME AGREED UPON BY THE PLANNING COMMISSION OR ITS REPRESENTATIVE AS OUTLINED IN THE PUBLIC IMPROVEMENTS AGREEMENT.

Charles Town Utility Board
832 S. GEORGE STREET, P.O. BOX 359, CHARLES TOWN, WV 25414
PHONE: (304) 725-2316 • FAX: (304) 725-4313

WATER VALVES DETAIL
STANDARD DETAIL NO. **W-3**
NOT TO SCALE
APRIL 2005

Charles Town Utility Board
832 S. GEORGE STREET, P.O. BOX 359, CHARLES TOWN, WV 25414
PHONE: (304) 725-2316 • FAX: (304) 725-4313

REPLACEMENT LATERAL CONNECTION DETAIL
STANDARD DETAIL NO. **S-14**
NOT TO SCALE
SEPTEMBER 2015

Charles Town Utility Board
832 S. GEORGE STREET, P.O. BOX 359, CHARLES TOWN, WV 25414
PHONE: (304) 725-2316 • FAX: (304) 725-4313

SEWER SADDLE DETAIL
STANDARD DETAIL NO. **S-15**
NOT TO SCALE
SEPTEMBER 2015

Charles Town Utility Board
832 S. GEORGE STREET, P.O. BOX 359, CHARLES TOWN, WV 25414
PHONE: (304) 725-2316 • FAX: (304) 725-4313

CITY OF RANSON POST-TOP STREETLIGHT DETAIL
NOT TO SCALE

Charles Town Utility Board
832 S. GEORGE STREET, P.O. BOX 359, CHARLES TOWN, WV 25414
PHONE: (304) 725-2316 • FAX: (304) 725-4313

WATER VALVES DETAIL
STANDARD DETAIL NO. **W-3**
NOT TO SCALE
APRIL 2005

Charles Town Utility Board
832 S. GEORGE STREET, P.O. BOX 359, CHARLES TOWN, WV 25414
PHONE: (304) 725-2316 • FAX: (304) 725-4313

REPLACEMENT LATERAL CONNECTION DETAIL
STANDARD DETAIL NO. **S-14**
NOT TO SCALE
SEPTEMBER 2015

Charles Town Utility Board
832 S. GEORGE STREET, P.O. BOX 359, CHARLES TOWN, WV 25414
PHONE: (304) 725-2316 • FAX: (304) 725-4313

SEWER SADDLE DETAIL
STANDARD DETAIL NO. **S-15**
NOT TO SCALE
SEPTEMBER 2015

Charles Town Utility Board
832 S. GEORGE STREET, P.O. BOX 359, CHARLES TOWN, WV 25414
PHONE: (304) 725-2316 • FAX: (304) 725-4313

CITY OF RANSON POST-TOP STREETLIGHT DETAIL
NOT TO SCALE

Charles Town Utility Board
832 S. GEORGE STREET, P.O. BOX 359, CHARLES TOWN, WV 25414
PHONE: (304) 725-2316 • FAX: (304) 725-4313

WATER VALVES DETAIL
STANDARD DETAIL NO. **W-3**
NOT TO SCALE
APRIL 2005

Charles Town Utility Board
832 S. GEORGE STREET, P.O. BOX 359, CHARLES TOWN, WV 25414
PHONE: (304) 725-2316 • FAX: (304) 725-4313

REPLACEMENT LATERAL CONNECTION DETAIL
STANDARD DETAIL NO. **S-14**
NOT TO SCALE
SEPTEMBER 2015

Charles Town Utility Board
832 S. GEORGE STREET, P.O. BOX 359, CHARLES TOWN, WV 25414
PHONE: (304) 725-2316 • FAX: (304) 725-4313

SEWER SADDLE DETAIL
STANDARD DETAIL NO. **S-15**
NOT TO SCALE
SEPTEMBER 2015

Charles Town Utility Board
832 S. GEORGE STREET, P.O. BOX 359, CHARLES TOWN, WV 25414
PHONE: (304) 725-2316 • FAX: (304) 725-4313

CITY OF RANSON POST-TOP STREETLIGHT DETAIL
NOT TO SCALE

Charles Town Utility Board
832 S. GEORGE STREET, P.O. BOX 359, CHARLES TOWN, WV 25414
PHONE: (304) 725-2316 • FAX: (304) 725-4313